

# MODULOR

5 MODULOR  
6 LIVING, 56 NIGHT, 80 OFFICE, 96 LOUNGE

[rimadesio-wien.at](http://rimadesio-wien.at)

INDEX



IT Un sistema di boiserie attrezzate, una nuova soluzione per qualificare, attrezzare e personalizzare le superfici degli ambienti domestici e di lavoro. Sempre su misura, adattabile ad ogni situazione architettonica, Modulor permette di creare geometrie ordinate o composte, e di scegliere tra un'ampia varietà di materiali e finiture esclusive. Modulor è disponibile con vani attrezzati per la zona giorno e l'area notte; i contenitori si integrano perfettamente nella pannellatura a effetto continuo della boiserie.

DE Ein Vertäfelungssystem für die Einrichtung, eine neue Lösung, um die Oberflächen von Wohn- und Arbeitsbereichen zu gestalten, nachzurüsten und zu personalisieren. Modulor wird immer nach Maß gefertigt und passt sich jeder architektonischen Situation an. Sie können geordnete oder komplexe Geometrien erstellen und aus einer Vielzahl von Materialien und exklusiven Oberflächen wählen. Modulor ist mit ausgestatteten Fächern für den Wohn- und Schlafbereich erhältlich; die Behälter sind perfekt in die durchgehende Verkleidung integriert.

FR Un système de boiserie équipées, une nouvelle solution pour définir, équiper et personnaliser les surfaces des espaces intérieurs domestiques et professionnels. Toujours sur mesure, en mesure de s'adapter à toute situation architecturale, Modulor permet de créer des géométries organisées ou composées, et de choisir parmi une grande variété de matériaux et de finitions exclusives. Modulor est disponible avec des compartiments équipés pour la zone jour et la zone nuit; les rangements s'intègrent parfaitement dans les panneaux à effet continu des boiserie.

ES Un sistema de revestimiento equipado, una nueva solución para calificar, equipar y personalizar las superficies de los ambientes domésticos y laborales. Siempre a medida, adaptable a cualquier situación arquitectónica, Modulor permite crear geometrías ordenadas o compuestas, y elegir entre una amplia variedad de materiales y acabados exclusivos. Modulor está disponible con compartimentos equipados para la zona de estar y la zona de dormitorio; Los contenedores se integran perfectamente en los paneles de efecto continuo del revestimiento.

RU Оборудованная система стеновых панелей (буазери) – новое решение для отделки, оснащения и индивидуализации поверхностей в жилых и офисных помещениях. Система Modulor всегда изготавливается на заказ в соответствии с конкретными архитектурными условиями и позволяет создавать простые или составные геометрические формы, а также отличается широким ассортиментом материала и эксклюзивной фурнитурой. Система Modulor выполнена с оборудованными секциями для зон гостиной и спальни. Контейнеры идеально встраиваются в стеновые панели, создавая эффект непрерывной поверхности.

汉语 这套配件式护墙板系统是一项为居家和工作环境提供装饰、配件和定制的全新解决方案。Modulor 皆按尺寸定制，创造出有条不紊与组合性的几何，可融入各式建筑场景中，并有多样材质和独特的饰面可供选择。Modulor 可为日间空间和卧室装配开放式收纳格；柜体与呈现延伸效果的墙板完美融合。

AN EQUIPPED BOISERIE SYSTEM, A NEW SOLUTION FOR DISTINGUISHING, EQUIPPING AND CUSTOMISING THE SURFACES IN HOME AND WORK ENVIRONMENTS. ALWAYS MADE TO MEASURE AND ADAPTABLE TO ANY ARCHITECTURAL SITUATION, MODULOR ALLOWS TO CREATE ORDERED OR COMPOUND GEOMETRIES, AND TO CHOOSE FROM A WIDE VARIETY OF MATERIALS AND EXCLUSIVE FINISHINGS. MODULOR IS AVAILABLE WITH EQUIPPED COMPARTMENTS FOR THE LIVING AND NIGHT AREA; THE STORAGE UNITS ARE PERFECTLY INTEGRATED INTO THE CONTINUOUS-EFFECT PANELLING OF THE BOISERIE.



MODULOR IS AN INTERIOR WALL PANELLING SYSTEM OF THE LATEST CONCEPT. A PURE SURFACE, PUNCTUATED BY HORIZONTAL AND VERTICAL STRUCTURAL PROFILES ON WHICH SUSPENDED CONTAINERS MADE ENTIRELY OF GLASS, THIN SHELVES AND HORIZONTAL OR VERTICAL SHOWCASES ARE INSERTED. A PERFECT TRAIT D'UNION LINKING THE DIFFERENT TYPOLOGICAL FUNCTIONS OF THE COLLECTION WITH INTERIOR ARCHITECTURE.

IT Modulor è un sistema boiserie da interni di nuova concezione. Una superficie pura, scandita da profili strutturali orizzontali e verticali su cui si innestano contenitori sospesi interamente in vetro, mensole dallo spessore sottilissimo e vetrine orizzontali o verticali. Un perfetto trait d'union che collega le diverse funzioni tipologiche della collezione con l'architettura d'interni.

DE Modulor ist ein neu entwickeltes Vertäfelungssystem für Innenräume. Eine klare Oberfläche, die von horizontalen und vertikalen Strukturprofilen unterbrochen wird, auf die Hängebehälter aus Glas, feinste Ablagen und horizontale oder vertikale Vitrinen aufgesetzt sind. Ein perfektes Bindeglied zwischen den verschiedenen Funktionstypen der Kollektion und der bestehenden Innenarchitektur.

FR Modulor est un système innovant de boiseries pour intérieurs. Une surface pure, rythmée par des profils structurels horizontaux et verticaux sur lesquels viennent se fixer des rangements suspendus entièrement en verre, des étagères très fines et des vitrines horizontales ou verticales. Un trait d'union parfait qui relie les différentes fonctions typologiques de la collection à l'architecture d'intérieur.

ES Modulor es un sistema de revestimiento para interiores de nuevo diseño. Una superficie pura, punteada por perfiles estructurales horizontales y verticales sobre los que se insertan contenedores suspendidos totalmente de vidrio, estantes muy finos y vitrinas horizontales o verticales. Un perfecto rasgo de unión que conecta las diferentes funciones tipológicas de la colección con la arquitectura interior.

RU Modulor – это новая концепция системы стеновых панелей для помещений. Строгая поверхность, пронизанная горизонтальными и вертикальными опорными профилями, на которых крепятся подвесные стеклянные контейнеры, очень тонкие полки и горизонтальные и вертикальные витрины. Идеальное сочетание разнообразных типовых функций с архитектурой интерьера.

汉语 Modulor 为一套概念新颖的室内护墙板系统。垂直水平向的结构型材衬托出洁净的表面，在其之上悬挂着全玻璃制的柜体、极纤薄的层板和垂直水平向的玻璃展示柜。这项特色将系列中不同类型的功能与室内建筑完美结合。









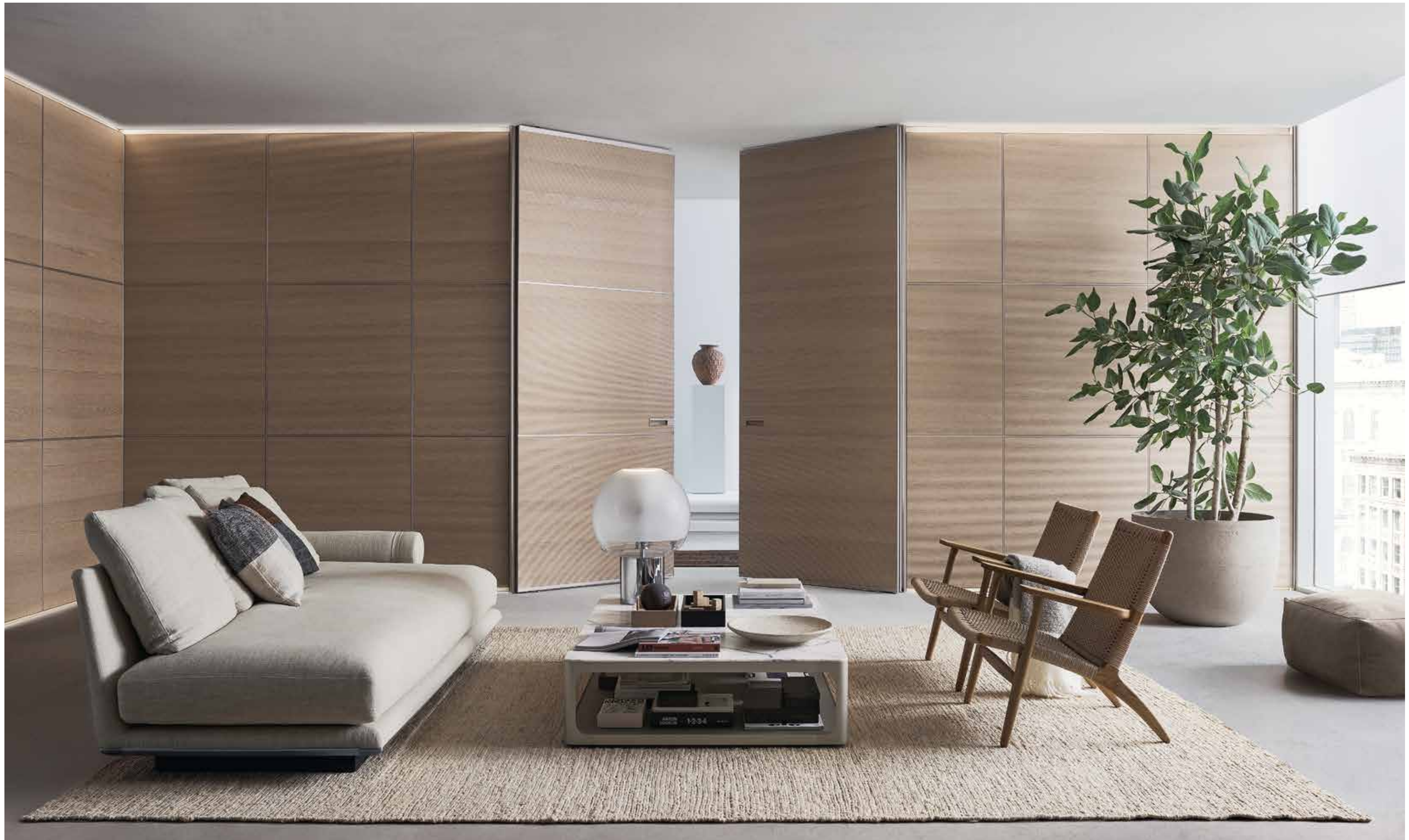





Structure: 303 bronzo  
Wood cladding: 20 rovere termotrattato sahara

In this photo  
Sliding door: Velaria  
Table: Long Island  
Suspended cabinet: Self bold





EN The Modulor system adapts to any existing architectural situation, integrating changes of ceiling heights with the maximum precision. The result is a whole wall solution, in which storage unit compartments, suspended elements and backlit shelves are integrated.

IT Il sistema Modulor si adatta a qualunque situazione architettonica preesistente, integrando con la massima precisione cambi di altezze a soffitto. Ne risulta una soluzione attrezzata a tutta parete, in cui si inseriscono vani contenitori, elementi sospesi e mensole retroilluminate.

DE Das Modulor-System passt sich jeder bestehenden architektonischen Situation an und integriert Änderungen der Deckenhöhen mit äußerster Präzision. Das Ergebnis ist ein Angebot, das die gesamte Wand ausnutzt und in Ablagefächer, Hänge-Elemente und hintergrundbeleuchtete Regale einteilt.

FR Le système Modulor s'adapte à toutes les situations architecturales préexistantes, en intégrant avec la plus grande précision les changements de hauteur au plafond. Il en résulte une solution équipée sur l'ensemble du mur, dans laquelle des compartiments conteneurs, des éléments suspendus et des étagères rétroéclairées viennent se fixer.

ES El sistema Modulor se adapta a cualquier situación arquitectónica existente, integrando los cambios de altura a techo con la máxima precisión. El resultado es una solución equipada para la totalidad de la pared, con huecos contenedores, elementos colgantes y estantes retroiluminados.

RU Система Modulor хорошо сочетается с любыми существующими архитектурными решениями и с максимальной точностью соответствует изменениям высоты потолка. Она представляет собой оборудованную систему панелей размером со всю стену, на которой крепятся различные контейнеры, подвесные элементы и полки с подсветкой.

汉语 Modulor 系统适用于当今现有的任何建筑场景，通过极精确的方式根据天花板的高度进行整合与调整。这是一项可配置收纳格、悬挂构件以及带背光层板的墙面配置解决方案。



Structure and shelves: 303 bronzo  
Wood cladding: 20 rovere termotrattato sahara  
Glass sides and back panel: 136 bronzo opaco  
Internal glass shelves: 63 grigio trasparente

In this photo  
Table: Long Island  
Suspended cabinet: Self bold





EN The equipped units of the Modulor system are designed to organize and store objects, in an orderly and functional solution. The storage unit elements integrate perfectly in the wall panelling system thanks to hinged doors with push opening, without visible handles. Inside, in addition to the optional led lighting system, the compartments can be customized with all the accessories included in the system.

IT I vani attrezzati del sistema Modulor sono progettati per organizzare e custodire oggetti, in una soluzione ordinata e funzionale. Gli elementi contenitori si integrano perfettamente nella boiserie grazie ad ante a scomparsa con apertura push, prive di maniglie a vista. All'interno, oltre al sistema di illuminazione led opzionale, i vani sono personalizzabili con tutte le attrezzature previste dal sistema.

DE Die ausgestatteten Fächer des Modulor-Systems dienen dazu, Objekte in einer geordneten und funktionalen Lösung zu organisieren und zu lagern. Die Aufbewahrungselemente fügen sich dank versenkbarer Türen mit Drucköffnung ohne sichtbare Griffe perfekt in die Boiserie ein. Im Inneren können zusätzlich zum optionalen LED-Beleuchtungssystem die Fächer mit allen vom System bereitgestellten Geräten angepasst werden.

FR Les compartiments équipés du système Modulor sont conçus pour organiser et ranger des objets, dans une solution ordonnée et fonctionnelle. Les éléments du rangement s'intègrent parfaitement dans la boiserie grâce à des portes avec ouverture à pression, sans poignées visibles. À l'intérieur, en plus du système d'éclairage led optionnel, les compartiments peuvent être personnalisés avec tous les équipements prévus par le système.

ES Los compartimentos equipados del sistema Modulor están diseñados para organizar y almacenar objetos de forma ordenada y funcional. Los elementos contenedor están perfectamente integrados en la boiserie, gracias a las puertas entre paredes con apertura push, sin tiradores visibles. En el interior, además del sistema de iluminación led opcional, los compartimentos pueden personalizarse con todo el equipamiento que ofrece el sistema.

RU Оборудованные секции системы Modulor предназначены для практичного и упорядоченного размещения и хранения предметов. Контейнеры идеально вписываются в буазери благодаря установленным заподлицо распашным дверцам без видимых ручек. Кроме выполняемой на заказ системы освещения со светодиодными лампочками, по индивидуальному заказу внутри секций может быть установлено все оборудование, предусмотренное для системы.

汉语 通过 Modulor 系统的收纳格配件, 物品可根据功能, 以有条不紊的方式妥善地保存和摆放。带推弹开启系统的隐藏式推拉门无明显外露的把手, 收纳构件与护墙板完美相融。在其内部, 除了 LED 照明系统可供选配之外, 亦能通过本系统所提供的配件为收纳格进行定制。

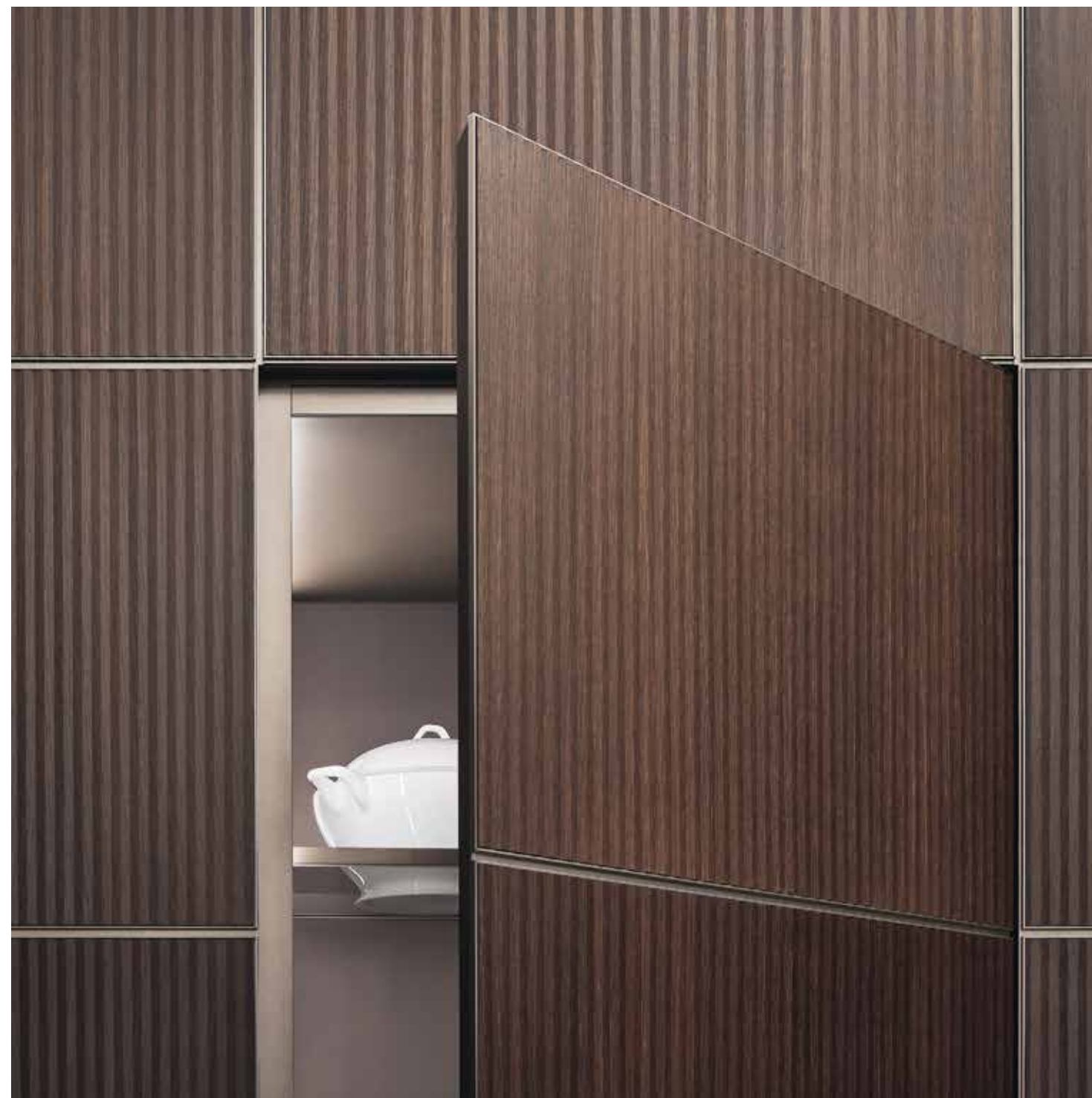

Structure: 303 bronzo  
Wood cladding: 20 rovere termotrattato sahara  
Glass sides and back panel: 136 bronzo opaco  
Internal glass shelves: 63 grigio trasparente







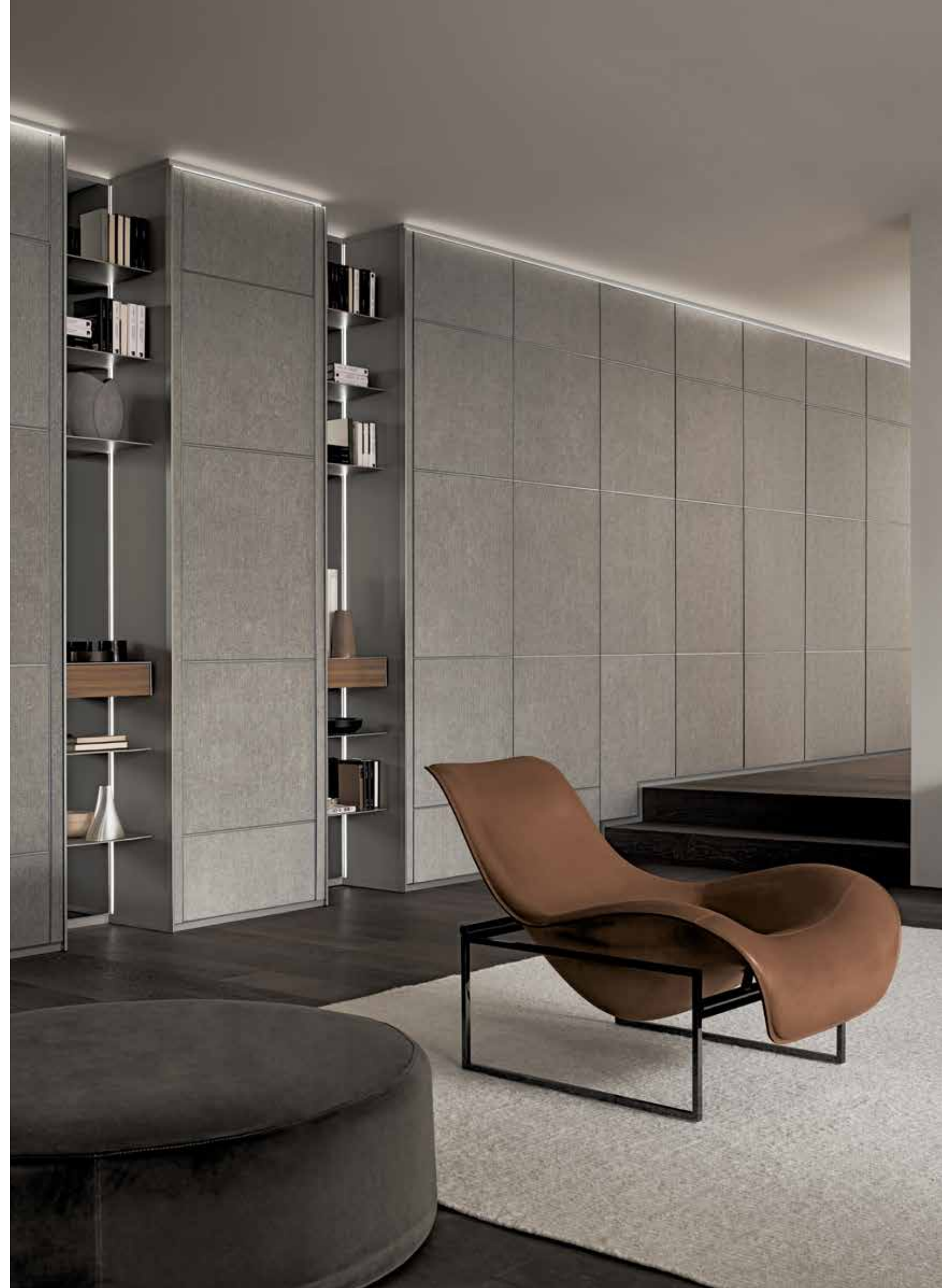





EN New equipped open units emphasize the linearity of the Modulor wall panelling system, with a highly scenographic result. Equipped with suspended drawers and 5 mm aluminium shelves, the elements give rhythm to the equipped wall, without altering its geometry. The Modulor system can perfectly integrate steps or height changes.

IT Inedite colonne a giorno scandiscono la linearità della boiserie Modulor, con una resa altamente scenografica. Attrezzabili con cassetti sospesi e ripiani in alluminio da 5 mm, gli elementi ritmano la parete attrezzata, senza alterarne la geometria. Il sistema Modulor è in grado di integrare perfettamente gradini o cambi di altezze.

DE Ungewöhnliche offene Spalten kennzeichnen die Linearität der Modulor-Boiserie mit einer stark szenografischen Darstellung. Ausgestattet mit hängenden Schubladen und 5-mm-Aluminiumböden verleihen die Elemente der Wand Pfiff, ohne ihre Geometrie zu verändern. Das Modulor-System ist in der Lage, Stufen oder Änderungen in Höhe perfekt zu integrieren.

FR Les nouveaux compartements ouverts distinguent la linéarité de la boiserie Modulor, avec un rendu particulièrement scénographique. Les éléments peuvent être équipés de tiroirs suspendus et d'étagères en aluminium de 5 mm, les nouveaux éléments rythment la cloison équipée, sans en altérer la géométrie. Le système Modulor permet d'intégrer parfaitement des marches ou des changements de hauteur.

ES Nuevas columnas abiertas marcan la linealidad de la boiserie Modulor, con un resultado altamente escenográfico. Equipados con cajones colgantes y estantes de aluminio de 5 mm, los elementos dan ritmo al sistema mural, sin alterar su geometría. El sistema Modulor puede integrar perfectamente peldaños o cambios de altura.

RU Необычные колонны дневной зоны подчеркивают линейность буазери Modulor, делая их очень эффектными. На них могут крепиться подвесные ящики и алюминиевые полки толщиной 5 мм, которые создают ритмическую картину настенного шкафа, не изменяя его форму. Система Modulor идеально подходит для стен с прилегающими ступенями или с изменяющейся высотой.

汉语 新型的开放柜/开放模块烘托出 Modulor 护墙板的线条感, 打造极佳的视觉效果。在这些构件之上还能加装悬挂式抽屉柜和 5 毫米厚的铝合金层板, 维持原有几何性的同时, 为壁面增添韵律感。Modulor 能够完美地与各类台阶和高度的变化相融。





Structure: 304 platino  
Cladding: G004 Litech grigio rigato  
Glass sides and back panel: 139 terracotta opaco  
Internal glass shelves: 63 grigio trasparente



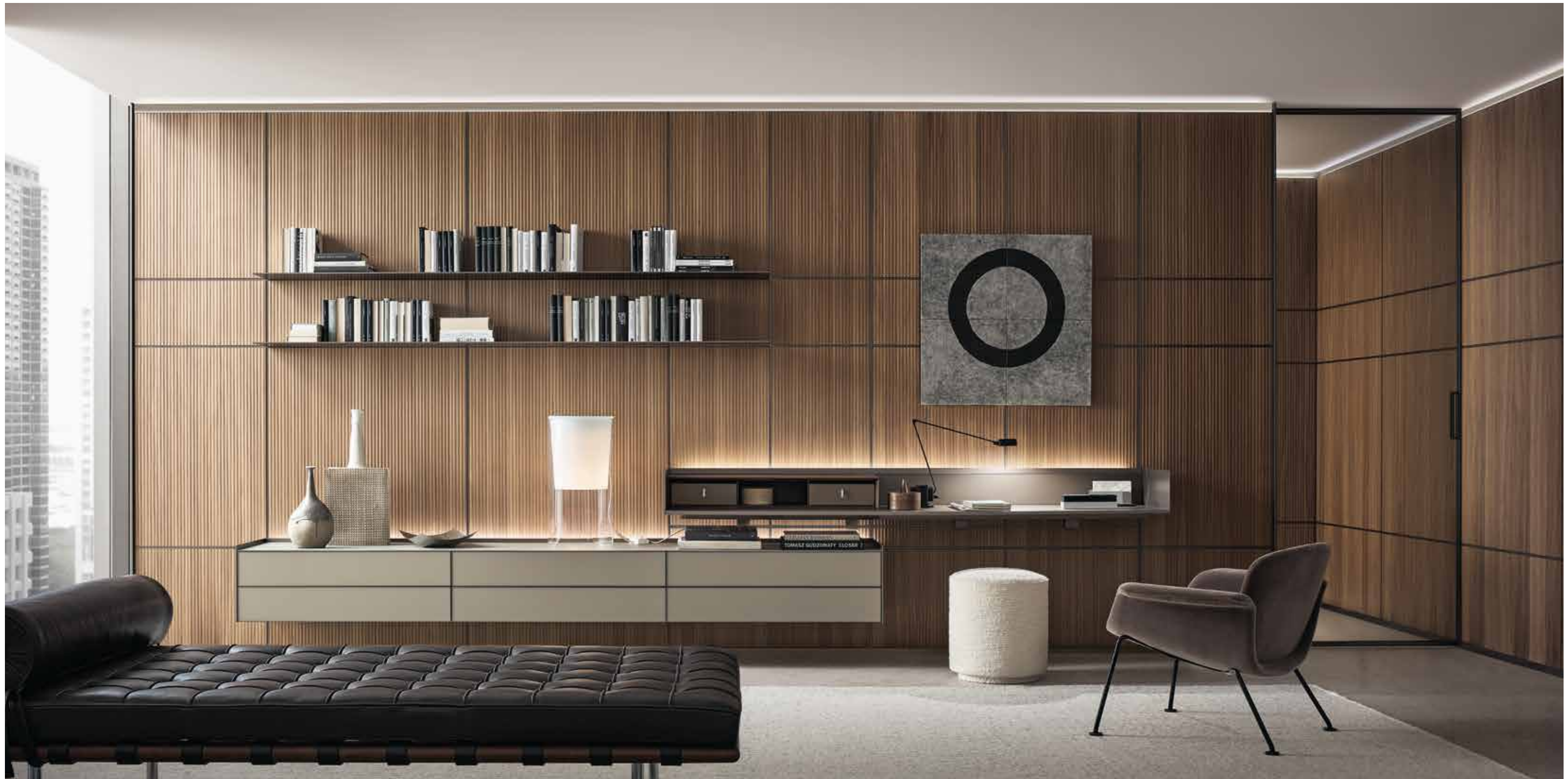



EN Among the innovative features of the Modolor system, there is the possibility to integrate all the Rimadesio sliding panels, except for the Graphis light model. As shown in the following pages, the Velaria panel slides into the wall panelling system and it is perfectly aligned with the jamb, designed to adapt to any differences in thickness between the walls. The sliding panel is provided with a built-in sliding rail, with a patented adjusting profile that allows its exact leveling and to counterbalance any differences in the ceiling height.

IT Tra le funzioni innovative previste del sistema Modolor, c'è la possibilità di integrare tutti i pannelli scorrevoli Rimadesio, ad eccezione del modello Graphis light. In queste pagine la porta Velaria si inserisce a scomparsa nella boiserie e si allinea perfettamente al copristipite, progettato per adattarsi a eventuali differenze di spessore tra le pareti. Il pannello scorrevole è dotato di binario di scorrimento a incasso, con profilo di aggiustaggio brevettato che consente un'esatta messa in bolla e la compensazione di eventuali dislivelli a soffitto.

DE Zu den innovativen Funktionen des Modolor-Systems gehört die Möglichkeit, alle Rimadesio-Schiebetüren mit Ausnahme des Graphis light-Modells zu integrieren. Auf diesen Seiten verschwindet die Velaria-Tür in der Boiserie und richtet sich perfekt auf die Kopfbedeckung aus, um sich an eventuelle Dickenunterschiede zwischen den Wänden anzupassen. Die Schiebetür mit einem Einbauschiene ist mit einer vertieften Gleitschiene mit einem patentierten Einstellprofil ausgestattet, das eine genaue Nivellierung und Kompensation von Unebenheiten in der Decke ermöglicht.

FR Parmi les fonctions innovantes prévues par le système Modolor, il y a la possibilité d'intégrer tous les panneaux coulissants Rimadesio, à l'exception du modèle Graphis light. Sur ces pages le panneau Velaria à galandage dans la boiserie, qui s'aligne parfaitement avec le jambage, conçu pour s'adapter à éventuelles différences d'épaisseur entre les cloisons. Le panneau coulissant est doté d'un rail encastré, avec un profil d'ajustement breveté qui permet une mise à niveau exacte et de compenser les éventuelles différences de niveau au plafond.

ES Entre las innovadoras funciones que ofrece el sistema Modolor, existe la posibilidad de integrar todos los paneles correderos de Rimadesio, a excepción del modelo Graphis light. En estas páginas, la puerta Velaria queda entre paredes en la boiserie y se alinea perfectamente con la cubrejamba, diseñada para adaptarse a cualquier diferencia de grosor entre las paredes. El panel corredero está equipado con una guía deslizante embutida, con un perfil de ajuste patentado que permite una nivelación exacta y la compensación de cualquier desnivel en el techo.

RU Одной из инновационных функций, предлагаемых системой Modolor, является возможность установки всех раздвижных панелей Rimadesio, за исключением модели Graphis light. На этих страницах показана дверь Velaria, которая встраивается в буазери заподлицо и идеально выравнивается с помощью наличника, разработанного с учетом разницы в толщине стен. Раздвижная панель оснащена утопленной направляющей с запатентованным регулировочным профилем, который позволяет точно выровнять и компенсировать любые неровности потолка.

汉语 Modolor 系统具备多项创新功能, 其中之一便是整合了 Rimadesio 所有型号的推拉门 ( Graphis light 除外)。在这几页所呈现的 Velaria 推拉门内藏在护墙板系统之中, 与门的包框完美对齐, 专为整合不同壁厚差而设计。推拉门搭配嵌入式滑轨, 其专利调节型材能够精确找平, 并补偿天花板的平整之处。

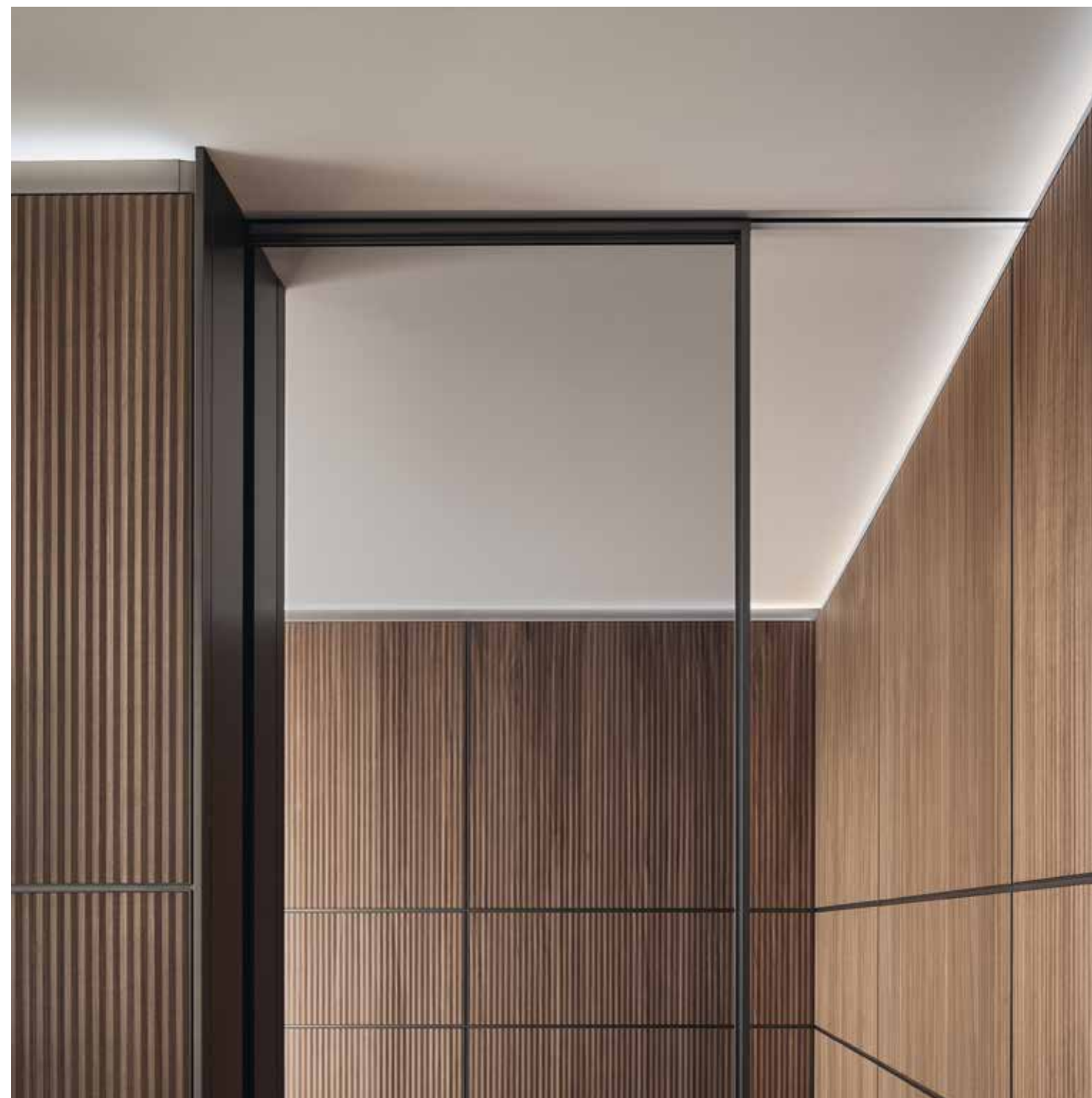

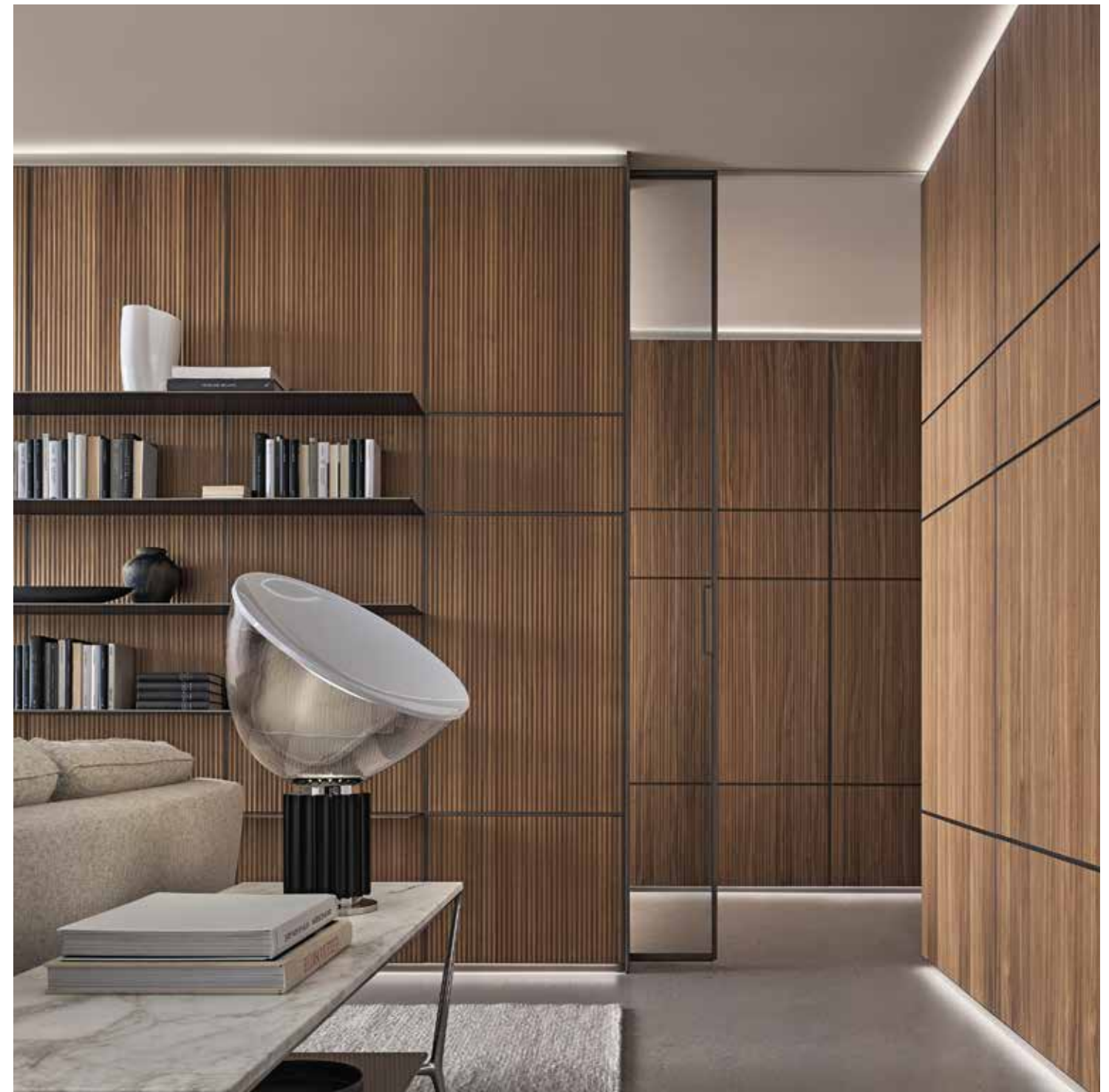
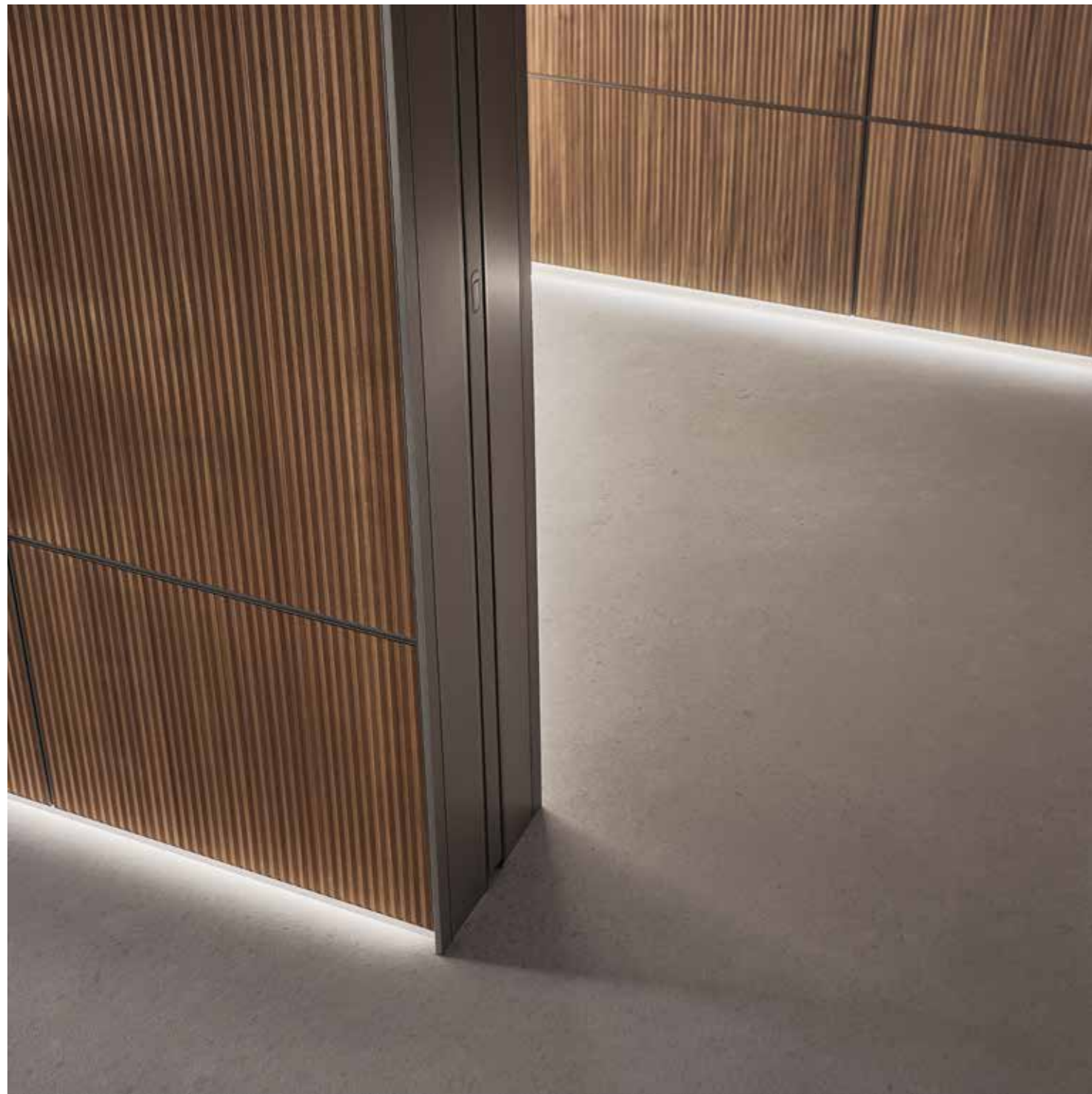







EN The Modulor swing door, always provided with a fixed fanlight panel, can be accessorized with the double-sided decorative crosspieces, thus integrating perfectly with the panelling. It is available in push or pull versions, always made to measure in width and height, and with all the claddings provided for the panelling.

IT La porta battente Modulor, sempre dotata di pannello sopra luce fisso, può essere accessoriata con i traversi decorativi bifacciali, integrandosi perfettamente alla boiserie. È disponibile nelle versioni a spingere o a tirare, sempre su misura in larghezza e altezza e con tutti i rivestimenti previsti per la boiserie.

DE Die mit einem festen Oberlichtpaneel ausgestattete ModulorFlügeltür, kann mit doppelseitigen Dekorpaneelen versehen werden, die sich perfekt in die Verkleidung einfügen. Sie ist als Stossen- oder Ziehentür erhältlich, immer in Breite und Höhe auf Maß gefertigt und für alle Verkleidungen der Boiserie vorgesehen.

FR La porte battante Modulor, toujours dotée de panneau à imposte fixe, peut être accessoirisée avec des traverses décoratives bifaces pour s'intégrer parfaitement à la boiserie. Elle est disponible dans les versions à pousser ou à tirer, toujours sur mesure en largeur et hauteur et avec tous les revêtements prévus pour la boiserie.

ES La puerta batiente Modulor, siempre equipada con un panel Superior hueco de luz fijo, puede equiparse con travesaños decorativos de doble cara, integrándose perfectamente con la boiserie. Está disponible en versiones push o pull, siempre hecho a medida en ancho y alto y con todo tapizado previsto para la boiserie.

RU Распашная дверь Modulor с неподвижной фрамугой может быть дополнена декоративными двусторонними перемычками, идеально сочетающимися с буазери. Дверь может открываться на себя или от себя и всегда изготавливается по индивидуальным размерам ширины и высоты с использованием покрытий, предусмотренных для буазери.

汉语 Modulor 铰链门皆配备固定的门楣/门头板, 可搭配双面的装饰性横梁, 与墙板完美融合。有推门和拉门两种型号可供选择, 宽度和高度皆按尺寸定制, 所有的墙板覆面皆可挑选。













Structure: 303 bronzo  
 Wood cladding: 20 rovere termotrattato sahara  
 Glass doors: 63 grigio trasparente  
 Glass sides and back panels: 136 bronzo opaco

Glass shelves: 63 grigio trasparente  
 Top, floor base and drawer units:  
 25 melaminico larice carbone  
 Synthetic leather drawer units top: 154 argilla

In this photo  
 Suspended cabinet: Self bold  
 Coffee table: Planet





EN Always custom-made, the storage units perfectly integrate in the wall panelling system with seamless effect. The frame doors create sophisticated display cases equipped with internal accessories that can be freely positioned in height, thanks to the exclusive patented system that allows to fix suspended drawer units, glass or wooden shelves, bottle shelves and pull-out trays in synthetic leather. The external dimmable LED lighting is integrated in the upper and lower horizontal profiles. A sensor led system is also available to light up the interior of the units.

IT Realizzati sempre su misura, i contenitori si integrano perfettamente nella pannellatura a effetto continuo della boiserie. Le ante a telaio consentono di creare sofisticate vetrine dotate di attrezzature interne liberamente posizionabili in altezza, grazie all'esclusivo sistema brevettato che permette di fissare cassettiere sospese, mensole in vetro o legno, ripiani portabottiglie e vassoi estraibili rivestiti in similpelle. L'illuminazione led dimmerabile esterna è incassata nei profili orizzontali superiori e inferiori. Disponibile anche un sistema led a sensore per illuminare l'interno dei vani.

DE Die Behälter sind immer maßgeschneidert und fügen sich perfekt in die durchgehende Effektverkleidung der Boiserie ein. Mit den Rahmentüren können Sie dank des exklusiven patentierten Systems, mit dem Sie hängende Kommoden, Regale aus Glas oder Holz, Flaschenregale und herausnehmbare Tablett aus Kunstleder befestigen können, anspruchsvolle Vitrinen mit internen Geräten erstellen, die frei in der Höhe positioniert werden können. Die dimmbare LED-Beleuchtung ist in das obere und untere horizontale Profil eingelassen. Zur Beleuchtung der Innenräume ist auch ein Sensor-LED-System erhältlich.

FR Toujours réalisés sur mesure, les conteneurs s'intègrent parfaitement dans le panneau à effet continu de la boiserie. Les portes avec châssis permettent de créer des vitrines sophistiquées dotées d'équipements internes, qui peuvent être librement positionnés en hauteur, grâce au système exclusif breveté qui permet de fixer des tiroirs suspendus, des portebouteilles et des extractibles en similicuir. L'éclairage led dimmable est encastré dans les profils horizontaux supérieurs et inférieurs. Un système led avec senseur pour éclairer les caissons intérieurs est également disponible.

ES Realizados siempre a medida, los contenedores se integran perfectamente en el sistema de paneles con efecto continuo de la boiserie. Las puertas de la estructura permiten crear sofisticadas vitrinas con equipamientos internos cuya altura puede variarse libremente, gracias al exclusivo sistema patentado que permite fijar cajoneras colgantes, baldas de cristal o madera, estantes botelleros y bandejas extraíbles revestidas de simil cuero. La iluminación led dimmable está embutida en los perfiles horizontales superiores e inferiores. También está disponible un sistema led con sensor para iluminar los huecos internos.

RU Контейнеры всегда выполняются по индивидуальному заказу и идеально встраиваются в стеновые панели, создавая эффект непрерывной поверхности. С помощью дверец с коробкой можно создавать изысканные витрины, которые оснащены внутренними приспособлениями, свободно размещаемыми по высоте благодаря эксклюзивной запатентованной системе. Эта система позволяет закреплять подвесные ящики, стеклянные или деревянные полки, полки для бутылок или выдвижные лотки, обтянутые искусственной кожей. Светодиодная подсветка с регулируемой яркостью установлена заподлицо в верхних и нижних горизонтальных профилях. Для освещения внутренних отсеков также используется система светодиодной подсветки с сенсорным управлением.

汉语 护墙板系统上的柜体皆按尺寸定制，与具有延伸效果的护墙板完美融合。这套系统的带框柜门打造出精致的展示柜，可自由安排内部构件的高度，通过独家专利技术，使这项设计能够配置悬挂式抽屉、玻璃或木质层架、酒架以及包覆仿真皮革的抽拉式皮篮。顶部和底部的水平型材嵌入了可调光的LED照明灯。亦有为收纳格内部照明的LED感应灯可供选择。

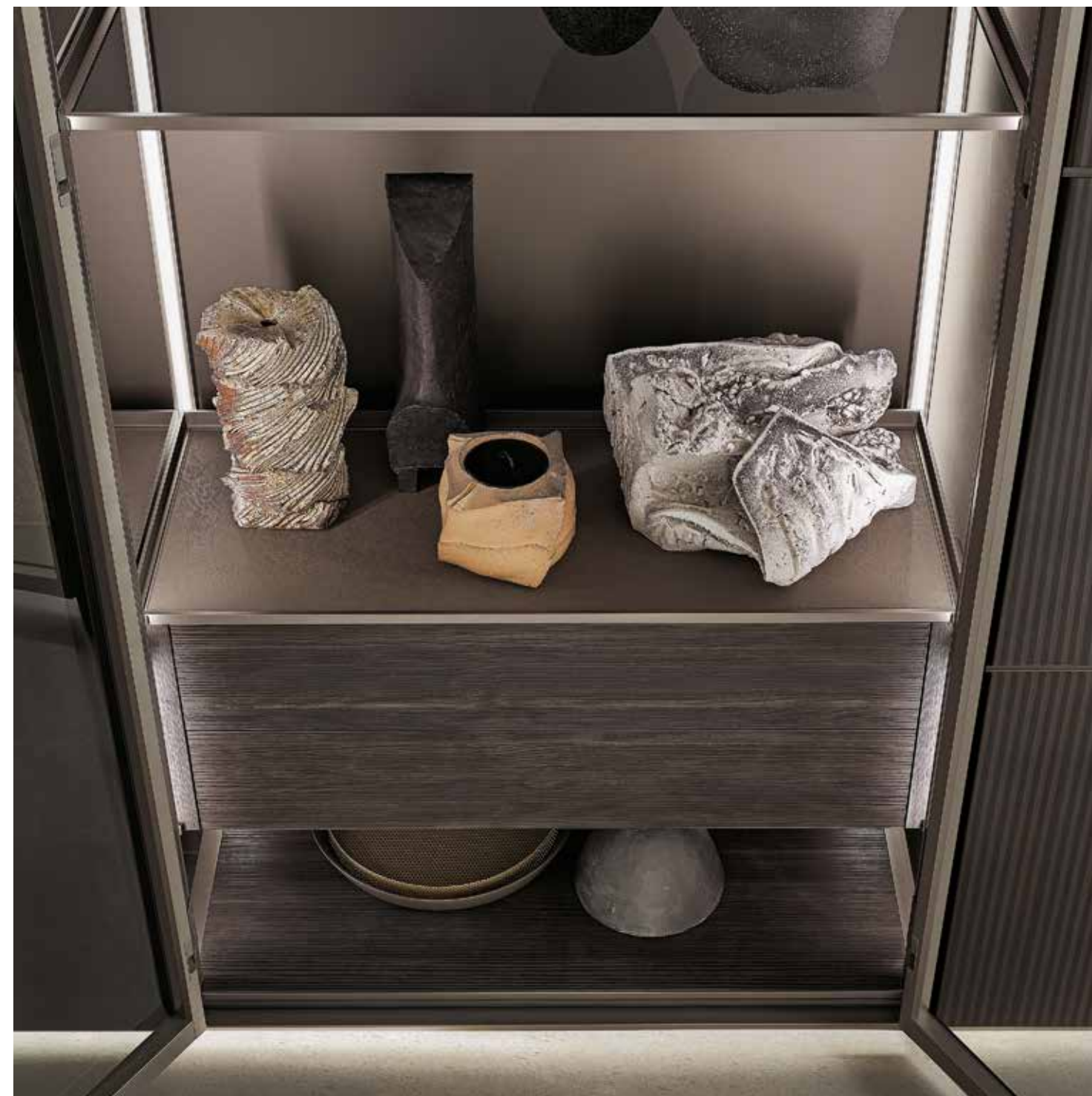

Structure: 303 bronzo  
Wood cladding: 20 rovere termotrattato sahara  
Glass doors: 63 grigio trasparente  
Glass sides and back panels: 136 bronzo opaco

Glass shelves: 63 grigio trasparente  
Top, floor base and drawer units:  
25 melaminico larice carbone  
Synthetic leather drawer units top: 154 argilla





IN THE NIGHT AREA, MODULOR INTEGRATES CUSTOMISED WARDROBE ELEMENTS INTO THE BOISERIE. A SOLUTION THAT IS ALWAYS MADE TO MEASURE, CONSISTING OF STORAGE UNITS THAT ALLOW THE FREE ARRANGEMENT OF THE EQUIPMENT, IN THE DESIRED TYPE AND HEIGHT, PERFECTLY INTEGRATED INTO THE CONTINUOUS-EFFECT PANELLING.

IT Nella zona notte, Modulor integra nella boiserie elementi guardaroba personalizzati. Una soluzione sempre su misura, composta da contenitori che consentono una libera disposizione delle attrezzature, nella tipologia e all'altezza desiderata, che si integrano perfettamente nella pannellatura a effetto continuo.

DE Im Schlafbereich integriert Modulor personalisierte Garderobenelemente in die Vertäfelungen. Eine Lösung nach Maß, bestehend aus Behältern, die eine freie Anordnung der Einrichtung in der gewünschten Art und Höhe ermöglichen und sich perfekt in die durchgehende Verkleidung integrieren.

FR Dans la zone nuit, Modulor intègre des éléments de penderie personnalisés dans les boiseries. Une solution toujours sur mesure, composée de rangements qui permettent une disposition libre des équipements, du type et de la hauteur souhaitée, qui s'intègrent parfaitement dans le panneau à effet continu.

ES En la zona de noche, Modulor integra elementos de armario personalizados en el revestimiento. Una solución siempre a medida, compuesta por contenedores que permiten la libre disposición de los equipos, en el tipo y altura deseada, que se integran perfectamente en el panelado de efecto continuo.

RU В зоне спальни в систему стеновых панелей Modulor встроены отдельные элементы гардероба. Решение выполняется по индивидуальному заказу и представляет собой контейнеры, позволяющие свободно разместить оборудование разного типа и высоты и идеально вписывающееся в буазери, создавая эффект непрерывной поверхности.

汉语 在卧室空间内, Modulor 能够将定制衣柜与护墙进行整合。这项解决方案皆按尺寸定制, 以各式柜体组成, 可依照所需的类型和高度自由进行配置、摆放, 它们与延伸效果的墙板完美融合。

EN The Modulor storage hinged door is designed to perfectly integrate in the wall panelling system thanks to the horizontal crosspieces that are aligned with the geometries of the panels, creating a solution of continuity. Discreet and almost imperceptible presence, the aluminium handle is also available in a recessed flush version with an optional lock for securely storing accessories, valuables and personal belongings. All doors are equipped with magnetic closing.

IT L'anta battente del sistema Modulor è progettata per integrarsi perfettamente nella boiserie grazie ai traversi orizzontali che si allineano alle geometrie della pannellatura, creando una soluzione di assoluta continuità. Presenza discreta e quasi impercettibile, la maniglia in alluminio è disponibile anche nella versione incassata a filo con serratura opzionale per custodire in sicurezza accessori, capi pregiati ed effetti personali. Tutte le ante sono dotate di chiusura magnetica.

DE Die Flügeltür des Modulor-Systems lässt sich dank der horizontalen Balken, die sich an den Geometrien der Verkleidung ausrichten, perfekt in die Holzverkleidung integrieren und schafft so eine Lösung für absolute Kontinuität. Der diskrete und kaum wahrnehmbare Aluminiumgriff ist auch in der Unterputzversion mit optionalem Schloss erhältlich, um Zubehör, wertvolle und persönliche Gegenstände sicher aufzubewahren. Alle Türen sind mit Magnetverschluss ausgestattet.

FR La porte battante du système Modulor est conçu pour s'intégrer parfaitement dans la boiserie grâce à des traverses horizontales qui s'alignent sur les géométries du panneau, en créant une solution de continuité absolue. Présence discrète et presque imperceptible, la poignée en aluminium est également disponible dans la version intégrée avec serrure en option pour conserver en toute sécurité les accessoires, habits de valeur et effets personnels. Tous les battants sont dotés d'une fermeture magnétique.

ES La puerta batiente del sistema Modulor está diseñada para integrarse perfectamente en la boiserie, gracias a los travesaños horizontales que se alinean a las geometrías del sistema de paneles, creando una solución de continuidad absoluta. Presencia discreta y casi imperceptible, la manilla en aluminio está disponible también en la versión embutida a ras con cerradura opcional, para guardar de forma segura accesorios, prendas de valor y efectos personales. Todas las puertas tienen cerradura magnética.

RU Распашная дверца системы Modulor идеально вписывается в буазери благодаря горизонтальным поперечным распоркам, которые совпадают с рисунком панельной обшивки, создавая эффект непрерывной поверхности. Почти незаметная алюминиевая ручка представлена также в исполнении с установкой заподлицо и снабжена замком (по заказу) для надежного хранения аксессуаров, ценных и личных вещей. Все двери оснащены магнитным замком.

汉语 Modulor 系统铰链门的设计与护墙板系统完美融合, 与墙板几何对齐的水平横梁打造出延伸感的解决方案。 铝合金把手的外观低调内敛, 亦有嵌入式版本可供选择; 可以选配锁, 安心存放各式配件以及贵重私人物品。 所有门板皆配备磁力锁。

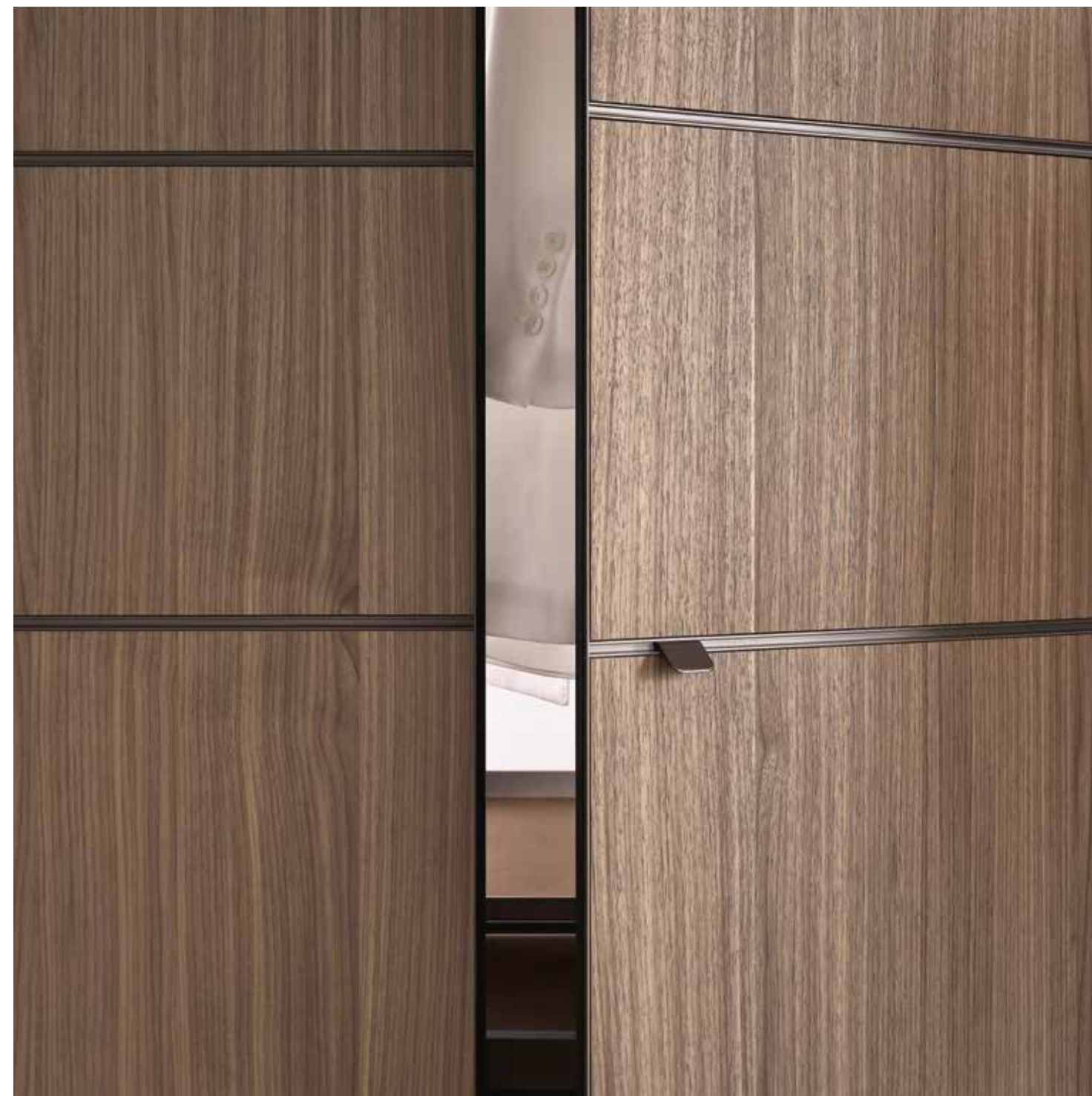

Structure: 303 bronzo  
Wood cladding: 17 noce sahara  
Glass back panel: 02 acidato extrachiaro  
Pull-out accessories in synthetic leather: 153 castoro



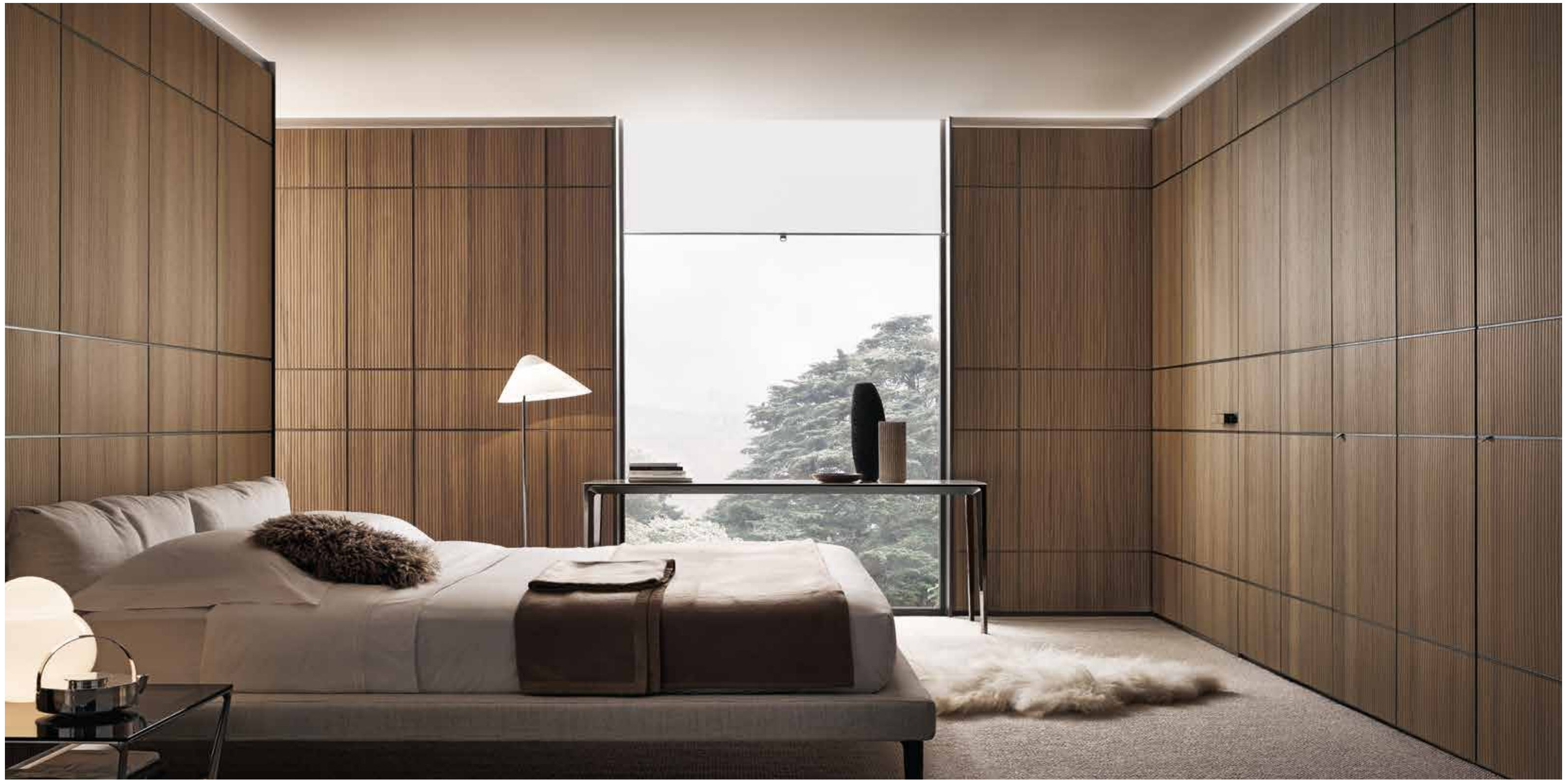

EN Modulator provides a new function in the bedroom that integrates customised wardrobe elements into the boiserie. The custom-made solution includes cabinets that allow a free arrangement of the equipment at the desired height. A further evolution that emphasizes a system capable of adapting to every architectural condition which can be equipped with doors, suspended furniture, passage openings and windows. It also allows to completely cover the walls with linear solutions, as well as with internal and external corners.

IT Modulator prevede nella zona notte un'inedita funzione che integra nella boiserie elementi guardaroba personalizzati. Una soluzione sempre su misura, composta da contenitori che consentono una libera disposizione delle attrezzature, nella tipologia e all'altezza desiderata. Un'ulteriore evoluzione che scandisce un sistema capace di adattarsi a ogni condizione architettonica, configurabile con porte, arredi sospesi, vani di passaggio e finestra. Il sistema permette inoltre di rivestire le pareti a effetto continuo con soluzioni lineari, nonché ad angolo interno ed esterno.

DE Modulator bietet im Schlafbereich eine völlig neue Funktion, bei der personalisierte Garderobenelemente in die Vertäfelungen integriert werden. Er kreiert eine immer maßgeschneiderte Lösung, bestehend aus Behältern, die eine freie Anordnung der Geräte in der Art und in der gewünschten Höhe ermöglichen. Eine weitere Entwicklung, die dieses System kennzeichnet, ist, dass es sich an jeden architektonischen Zustand anpassen und mit Türen, hängenden Möbeln, Durchgängen und Fenstern konfiguriert werden kann. Das System ermöglicht es auch, die Wände mit kontinuierlicher Wirkung mit linearen Lösungen sowie unter Innen- und Außenwinkeln abzudecken.

FR Modulator prévoit une fonction inédite dans la zone nuit, qui intègre des éléments de penderie personnalisés dans les boiseries. Une solution toujours sur mesure, composée de compartiments qui permettent de placer librement des équipements du type et de la hauteur souhaitée. Une évolution ultérieure qui caractérise un système en mesure de s'adapter à toutes les situations architecturales, qui peut être configuré avec portes, aménagements suspendus, compartiments de passage et fenêtre. Le système permet aussi de couvrir les murs avec un effet continu avec des solutions linéaires, ainsi qu'en angle intérieur et extérieur.

ES Modulator proporciona una nueva función en la zona de noche que integra elementos de armario personalizados en el revestimiento. Una solución siempre a medida, compuesta por contenedores que permiten una colocación libre de los equipamientos, del tipo y altura deseados. Una evolución más que recalca un sistema capaz de adaptarse a cualquier condición arquitectónica, configurable con puertas, muebles colgantes, huecos de paso y ventana. El sistema también permite revestir las paredes con efecto continuo y soluciones lineales, así como el ángulo interno y externo.

RU Для зоны спальни системой Modulator предлагается новая функция, с помощью которой в буазери встраиваются отдельные элементы гардероба. Решение осуществляется по индивидуальному заказу и представляет собой контейнеры, позволяющие свободно разместить оборудование требуемого типа и высоты. Дальнейшие преобразования привели к появлению системы, способной адаптироваться к любым архитектурным условиям, с возможностью изменения расположения дверей, подвесной мебели, проходов и окон. С помощью системы можно выполнить облицовку стен с непрерывным эффектом, используя линейные, и внутренние или внешние угловые решения.

汉语 Modulator 为卧室空间的一项全新功能为将定制衣柜构件嵌入护墙系统之中。这是一项定制的方案，其柜体皆可根据类型和需求高度自由配置。这套系统进一步的改良突出了它适用于各种建筑条件的能力，其可配置门、悬挂柜、通道和窗户。除此之外，这套系统可用线性和内外转角的解决方案来包覆延伸效果的墙面。











Structure: 303 bronzo  
 Glass cladding: 403 bronzo diamante  
 Glass back panels: 02 acidato extrachiaro  
 Internal glass shelves: 63 grigio trasparente  
 Drawer unit, floor base and top: 07 melaminico olmo  
 Clothes-hanger bar, drawers top and interior  
 in synthetic leather: 156 rubens

















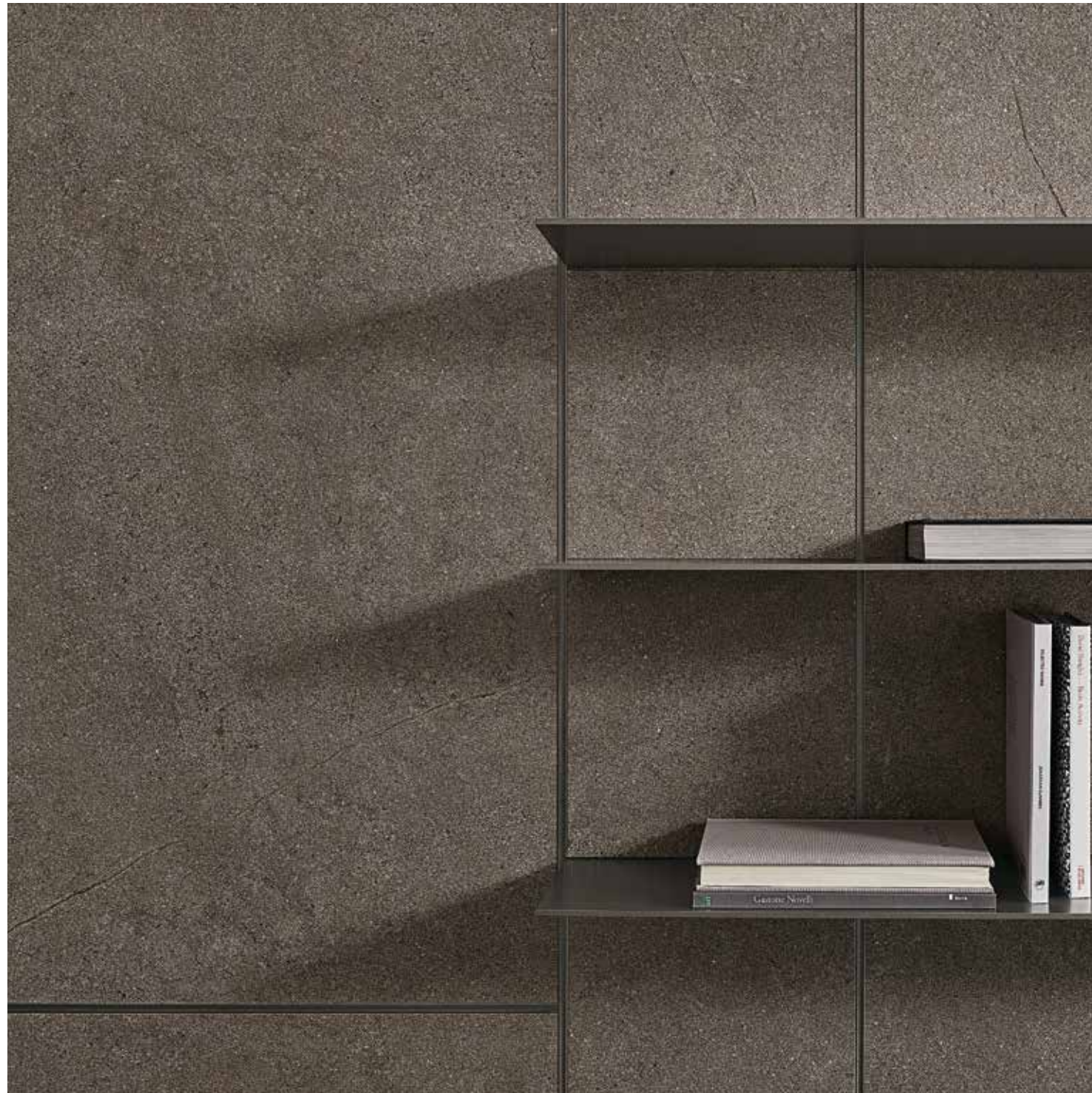









MODULOR IS ABLE TO INTERPRET THE NEEDS OF WORKSPACES, PROVIDING PRACTICAL AND FUNCTIONAL SOLUTIONS. THE VERSION WITH MICRO-PERFORATED ALUMINIUM SUPPORT AND SOUND-ABSORBING POLYESTER FIBRE IS AVAILABLE WITH LUX, MATERIAL AND TECH FABRIC CLADDINGS AND PROVIDES HIGH ACOUSTIC COMFORT FOR OFFICES.

IT Modulor permette di interpretare le esigenze degli spazi di lavoro, fornendo soluzioni concrete e funzionali. La versione con supporto in alluminio microforato e fibra di poliestere fonoassorbente è disponibile con rivestimento in tessuto lux, material e tech e garantisce un alto comfort acustico per gli uffici.

DE Modulor ermöglicht es, die Anforderungen von Arbeitsräumen zu interpretieren und bietet konkrete und funktionelle Lösungen. Die Version mit mikroperforiertem Aluminiumträger und schallabsorbierender Polyesterfaser ist mit Verkleidungen in den Ausführungen Lux, Material und Tech erhältlich und bietet hohen akustischen Komfort für Büros.

FR Modulor permet d'incarner les besoins des espaces de travail, et apporte des solutions concrètes et fonctionnelles. La version avec support en aluminium micro-perforé et fibre de polyester anti-bruit est disponible avec revêtement en tissu lux, material et tech et garantit un confort acoustique élevé pour les bureaux.

ES Modulor permite interpretar las necesidades de los espacios de trabajo, aportando soluciones concretas y funcionales. La versión con soporte de aluminio microperforado y fibra de poliéster fonoabsorbente está disponible con revestimiento en tejido lux, material y tech y garantiza un alto confort acústico para las oficinas.

RU Благодаря системе Modulor можно создать требуемые рабочие пространства, предлагая конкретные функциональные решения. Исполнение с использованием микроперфорированной алюминиевой опоры и звукопоглощающим полиэфирным волокном выполняется с покрытиями из тканей премиум класса и высокотехнологичных тканей и обеспечивает высокий уровень акустического комфорта в офисах.

汉语 Modulor 能够满足工作空间的各式需求, 提供具体而实用的解决方案。亦提供微孔铝支架搭配聚酯吸音纤维的版本, 饰面有 lux、material 和 tech 等面料可供选择, 为办公室提供高度舒适的隔音效果。

EN The Modulor panel can be divided by aluminium crosspieces which can be freely positioned on all the system centre distances. The crosspiece can be decorative, to create always different geometries, or structural, with the function of supporting shelves and suspended cabinets.

IT Il pannello Modulor può essere scandito dai traversi in alluminio, posizionabili liberamente su tutti gli interassi del sistema. Il traverso può essere decorativo, per creare geometrie sempre diverse, oppure strutturale, con la funzione di sostenere mensole e mobili sospesi.

DE Das Modulor-Panel kann durch die Aluminiumtraversen, die über alle Achsabstände des Systems frei positioniert werden können, unterteilt werden. Die Traversen können dekorativ sein, um verschiedene geometrische Figuren zu kreieren, oder strukturell, um Regale und Hängemöbel zu tragen.

FR Le panneau Modulor peut être décliné avec des traverses en aluminium, qui peuvent être librement placées sur tous les interaxes du système. La traverse peut être décorative pour créer des géométries toujours différentes, ou bien structurelle, avec pour fonction de supporter des étagères et des meubles suspendus.

ES El panel Modulor se puede dividir con travesaños de aluminio, que se pueden colocar libremente en todas las distancias entre ejes del sistema. El travesaño puede ser decorativo, para crear geometrías siempre cambiantes, o estructural, con la función de soportar baldas y muebles suspendidos.

RU Панель Modulor может быть выполнена с поперечными алюминиевыми распорками, которые можно свободно располагать на всех пролетах системы. Поперечная распорка имеет как декоративное назначение и используется для создания различного геометрического рисунка, так и конструкционное назначение и служит в качестве опоры для полок и подвесной мебели.

汉语 Modulor 系统的门板特色为其铝合金横梁,可在各个轴距之间自由定位。横梁可做装饰用途,创造出千变万化的几何图形;亦可做结构用途,支撑层板和悬挂柜。













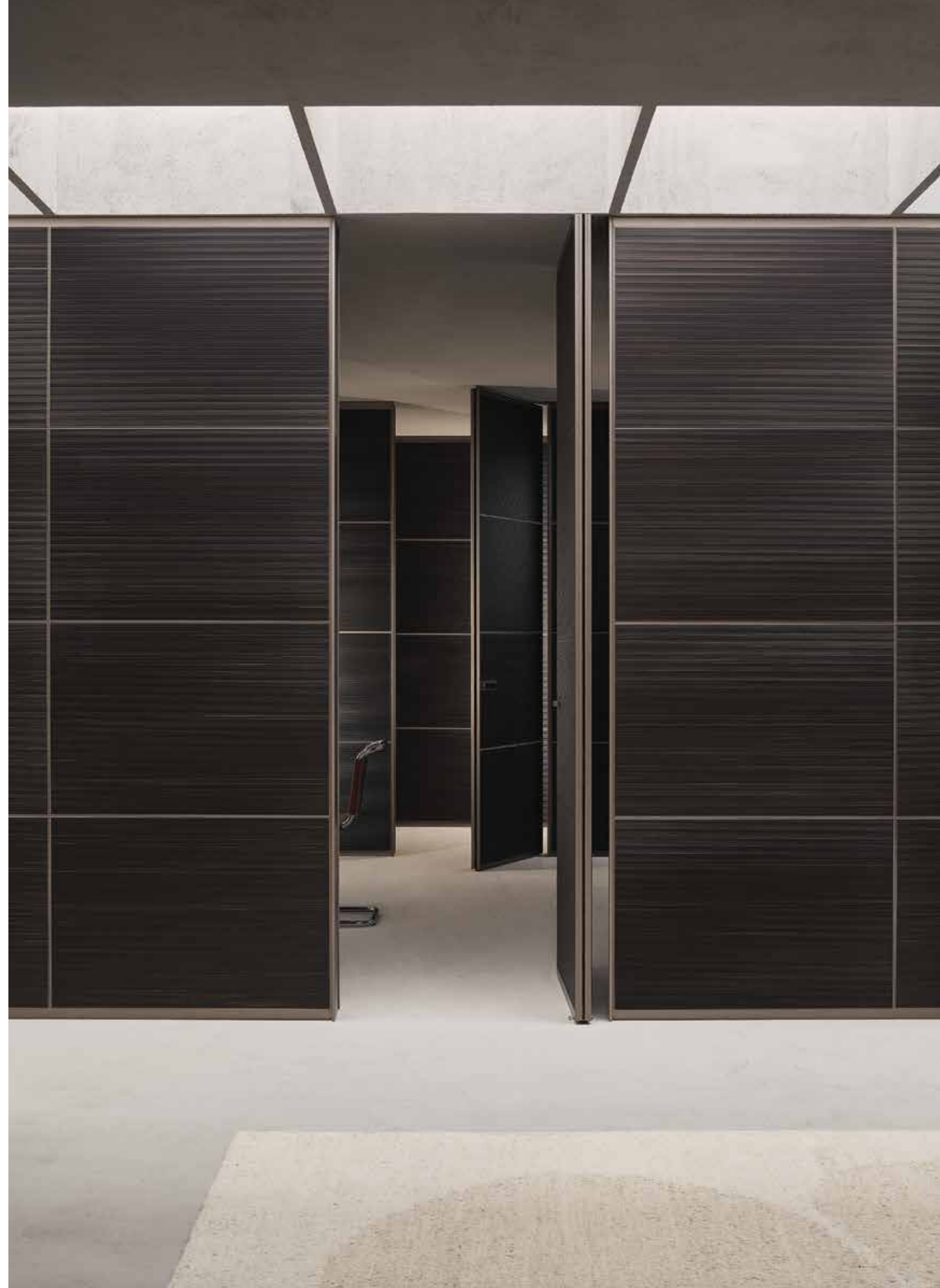





EN Modulor creates a link between the different typological functions of the Rimadesio collection and interior architecture. A project where the bespoke wall cladding dialogues with the Radius doors, in perfect continuity of design and finishing with the boiserie, connecting various rooms located in a space.

IT Modulor collega le diverse funzioni tipologiche della collezione Rimadesio con l'architettura d'interni. Un progetto in cui il rivestimento su misura della parete dialoga con le porte Radius, in perfetta continuità di disegno e finitura con le boiserie, collegando i vari ambienti di uno spazio.

DE Modulor verbindet die verschiedenen Funktionstypen der Rimadesio-Kollektion mit der vorhandenen Innenarchitektur. Ein Projekt, bei dem die maßgefertigten Wandverkleidungen mit den Radius-Türen in Dialog treten, eine perfekte Kontinuität mit dem Design und den Oberflächen der Vertäfelungen herstellen und die verschiedenen Bereiche eines Raumes miteinander verbinden.

FR Modulor relie les différentes fonctions typologiques de la collection Rimadesio à l'architecture d'intérieur. Un projet dans lequel le revêtement mural sur mesure communique avec les portes Radius, dans la parfaite continuité de conception et de finition avec les boiseries, reliant les différentes zones d'un espace.

ES Modulor conecta las diferentes funciones tipológicas de la colección Rimadesio con la arquitectura interior. Un proyecto en el que el revestimiento de pared a medida interactúa con las puertas Radius, en perfecta continuidad de diseño y acabado con el revestimiento, conectando las distintas estancias de un espacio.

RU Система Modulor соединяет различные типовые функции коллекции Rimadesio с архитектурой интерьера. Проект, в котором выполненная по индивидуальному заказу облицовка стен дополняется дверями Radius, идеально сочетающимися по дизайну с буазери, и объединяет различные помещения в единое пространство.

汉语 Modulor 将系列中各类型的功能与室内建筑对应连接。在这个项目中,定制的覆面墙面与 Radius 门和谐搭配,设计和饰面同护墙系统打造出完美的延伸感,将空间里的多个区域连接起来。

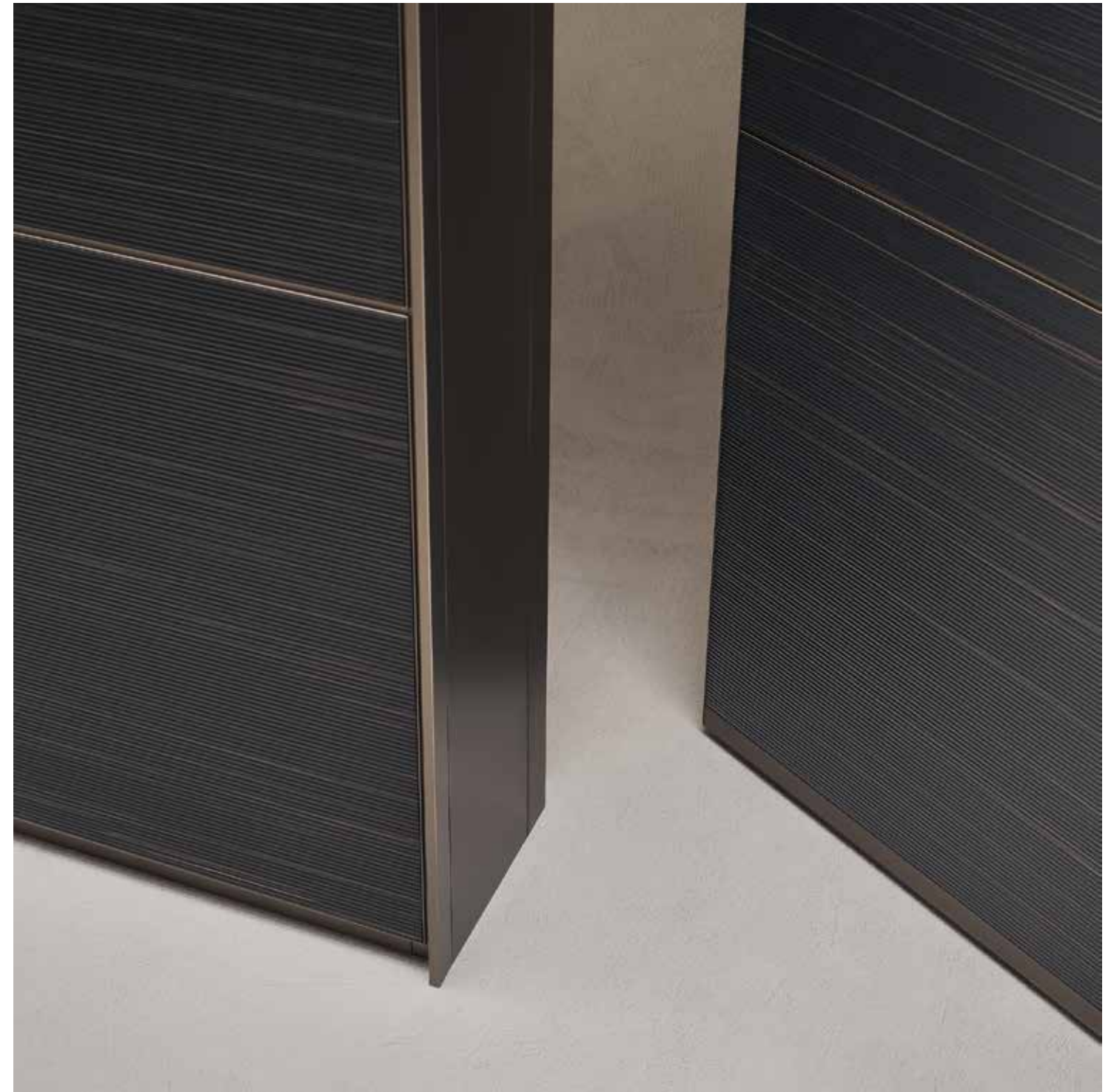



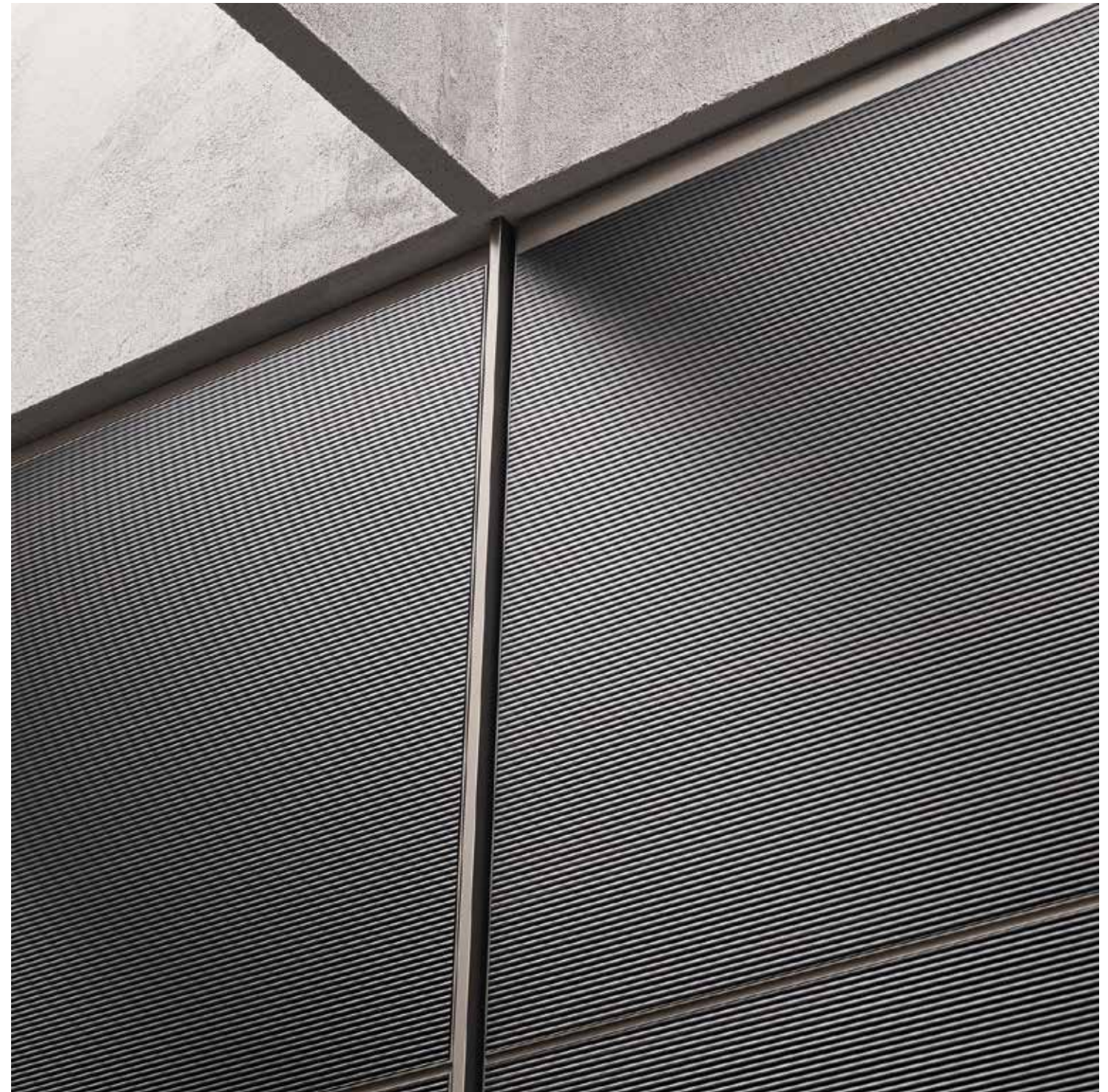





AN ENVIRONMENT THAT EMPHASISES ALL THE QUALITIES OF THE MODULOR BOISERIE SYSTEM: THE ABILITY TO ADAPT TO ANY ARCHITECTURAL CONDITION, THE COMPLETENESS OF THE EQUIPMENT, THE VARIETY OF THE FINISHINGS. MODULOR IS AVAILABLE IN A FIRE RESISTANT TECH VERSION IDEAL FOR THE HOTEL, RETAIL AND CONTRACT SECTORS. THANKS TO THE EXISTING TYPES OF PROFILES AND FILLERS, IT IS POSSIBLE TO CREATE FULL-HEIGHT OR PARTIAL-HEIGHT PASSAGES AND TO FINISH EXISTING ARCHITECTURAL ELEMENTS SUCH WINDOWS, ENTRANCE DOORS AND RADIATORS.

IT Un ambiente che sottolinea tutte le qualità del sistema boiserie Modulor: la capacità di adattarsi ad ogni condizione architettonica, la completezza delle attrezzature, la varietà delle finiture. Modulor è disponibile con rivestimento in versione tech resistente al fuoco ideale per l'hotellerie, il retail e il contract. Grazie alle tipologie di profili e fasce disponibili, è possibile realizzare passaggi a tutta altezza o ad altezza parziale e rifinire elementi architettonici preesistenti come serramenti, portoncini d'ingresso, caloriferi.

DE Eine Umgebung, die alle Qualitäten des Vertäfelungssystems Modulor zutage treten lässt: die Anpassungsfähigkeit an jede bestehende Architektur, die Vollständigkeit der Ausstattung, die Vielfalt der Oberflächen. Modulor ist mit einer Verkleidung in einer feuerfesten Tech-Version erhältlich, die ideal für den Hotel-, Einzelhandels- und Objektbereich ist. Dank der vorhandenen Profil- und Seitentypen ist es möglich, Durchgänge in voller oder reduzierter Höhe zu schaffen und bestehende architektonische Elemente wie Fenster und Türen, Nebeneingänge und Heizkörper zu veredeln.

FR Un environnement qui souligne toutes les qualités du système de boiseries Modulor: la capacité d'adaptation à toutes les conditions architecturales, le caractère exhaustif des équipements, la diversité des finitions. Modulor est disponible avec un revêtement en version tech, résistant au feu, idéal pour les hôtels, commerces et projets clé en main. Grâce aux types de profils et de bandeaux existants, il est possible de créer des passages du sol au plafond ou sur une hauteur partielle et de procéder aux finitions des éléments architecturaux préexistants tels que fenêtres, portes d'entrée, radiateurs.

ES Un ambiente que destaca todas las cualidades del sistema de revestimiento Modulor: la capacidad de adaptarse a cualquier condición arquitectónica, la integridad del equipamiento, la diversidad de acabados. Modulor está disponible con revestimiento en versión tech resistente al fuego, ideal para hostelería, comercio y contract. Gracias a los tipos de perfiles y bandas existentes, es posible crear pasillos de altura total o parcial y rematar elementos arquitectónicos existentes como ventanas, puertas de entrada, radiadores.

RU Обстановка, подчеркивающая все достоинства системы буазери Modulor: способность адаптироваться к любым архитектурным условиям, полный комплект оборудования, разнообразие отделки. Система Modulor выпускается в исполнении из огнестойкого высокотехнологичного материала, идеально подходящего для гостиниц, торговых и бизнес-центров. С помощью существующих профилей и полос можно создавать проходы на полную или частичную высоту помещения, а также отделывать существующие архитектурные элементы, такие как дверные и оконные коробки, входные двери и радиаторы отопления.

汉语 这个空间凸显出 Modulor 护墙系统的所有品质：适用于各种建筑条件的能力、齐全的配件和多样的饰面。Modulor 提供科技防火覆面的版本，为酒店、零售和商务空间的理想选择。通过使用现有型材和带材打造出全高或局部高度的通道，同时美化装饰现有的建筑构件（如：门窗框、玄关、暖气设备）。





Structure: 304 platino  
Litech cladding: G001 crema

Structure: 304 platino  
Synthetic leather cladding: 154 argilla

In this photo  
Console: Long Island  
Partition wall system: Spazio  
Sliding doors: Sail









Structure: 304 platino  
Litech cladding: G001 crema

Structure: 304 platino  
Synthetic leather cladding: 154 argilla

In this photo  
Partition wall system: Spazio  
Coffee table: Tray  
Suspended cabinets: Alambra





Modular structure

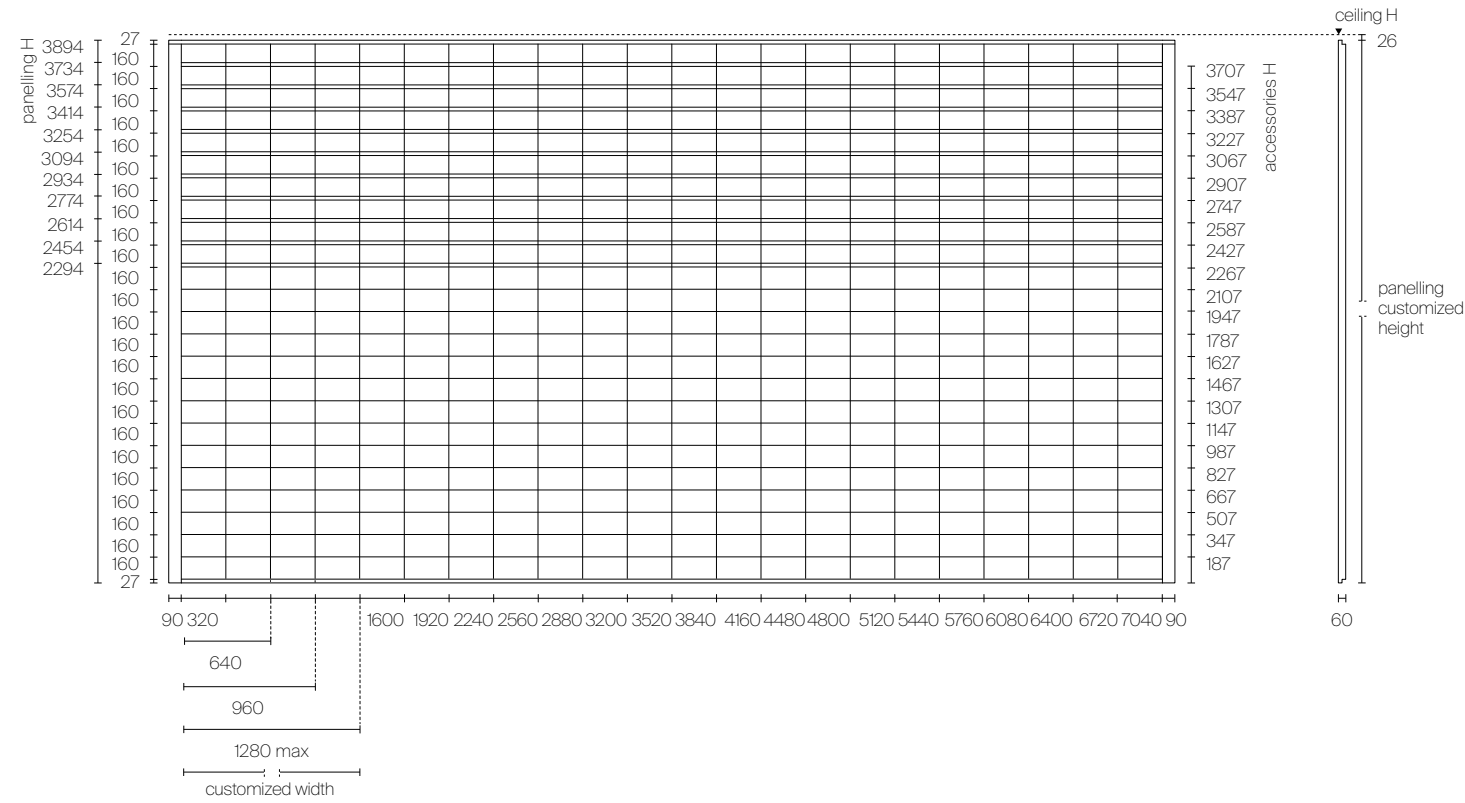

TECHNICAL DESCRIPTION

EN The panels are available in four widths (320, 640, 960, 1280 mm) and allow to design in total freedom, thanks to the modularity with a distance of 320 mm. The realization of the always custom made wall panelling is available up to the maximum height of 3894 mm. There is also a panel available with a width of 1600 mm and a maximum height of 3094 mm, dedicated exclusively to open units.

FR Les panneaux sont disponibles en quatre largeurs (320, 640, 960, 1280 mm) et permettent de faire un projet en toute liberté, grâce à sa modularité avec pas de 320 mm. La réalisation de la boiserie, toujours sur mesure, est disponible jusqu'à une hauteur maximale de 3894 mm. Un panneau de largeur 1600 mm est également disponible avec une hauteur maximale de 3094 mm exclusivement consacrée aux colonnes ouvertes.

RU Панели выпускаются с четырьмя вариантами ширины (320, 640, 960, 1280 мм) и обеспечивают полную свободу дизайна благодаря модульной конструкции с шагом 320 мм. По индивидуальному заказу можно выполнить стеновую панель с максимальной высотой 3894 мм. Кроме того, есть панель шириной 1600 мм с максимальной высотой 3094 мм, предназначенная исключительно для колонн в зоне гостиной.

ES Los paneles están disponibles en cuatro anchos (320, 640, 960, 1280 mm) y permiten diseñar con total libertad gracias a la modularidad con un paso de 320 mm. La realización de la boiserie, siempre hecha a medida, está permitida hasta la altura máxima de 3894 mm. También está disponible un panel en ancho 1600 mm y con altura máxima 3094 mm, dedicado exclusivamente a las columnas abiertas.

汉语 有四种宽度的门板 (320、640、960 和 1280 毫米) 可供选择, 间距为 320 毫米的模块化设计实现全然的设计自由。开放柜/开放模块皆按尺寸定制, 最大高度可达 3894 毫米。除此之外, 亦提供宽度 1600 毫米、高度最大至 3094 毫米的门板, 仅限开放柜/开放模块使用。

DE Diese Paneele sind in vier Breiten (320, 640, 960, 1280 mm) erhältlich und erlauben eine totale freie Planung, dies dank der Modularität von 320 mm Schritt. Die Herstellung der Wandverkleidung, welche immer nach Mass erfolgt, ist bis zu einer maximalen Höhe von 3894 mm erhältlich. Es ist auch ein Paneel in der Breite 1600 mm und einer maximalen Höhe von 3094 mm erhältlich.

Panel without pattern lines

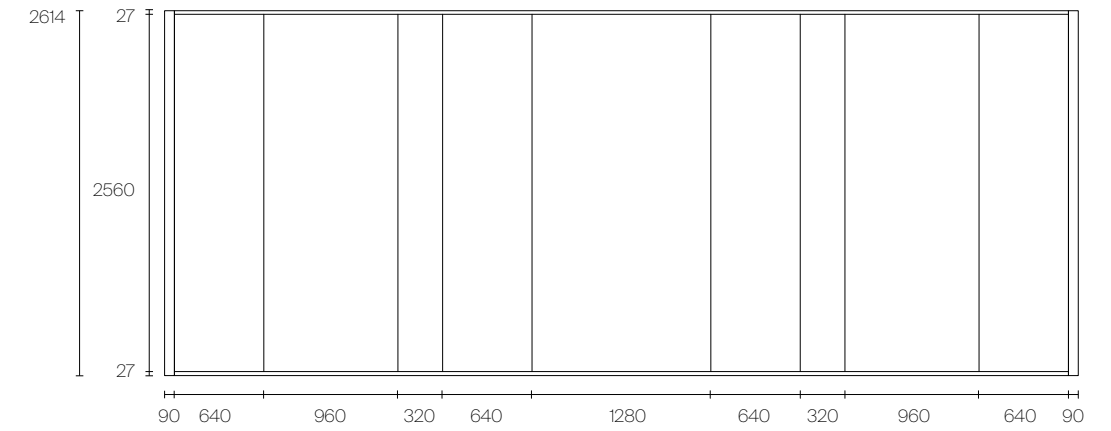
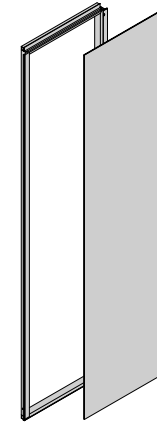

Squared pattern panel to be equipped

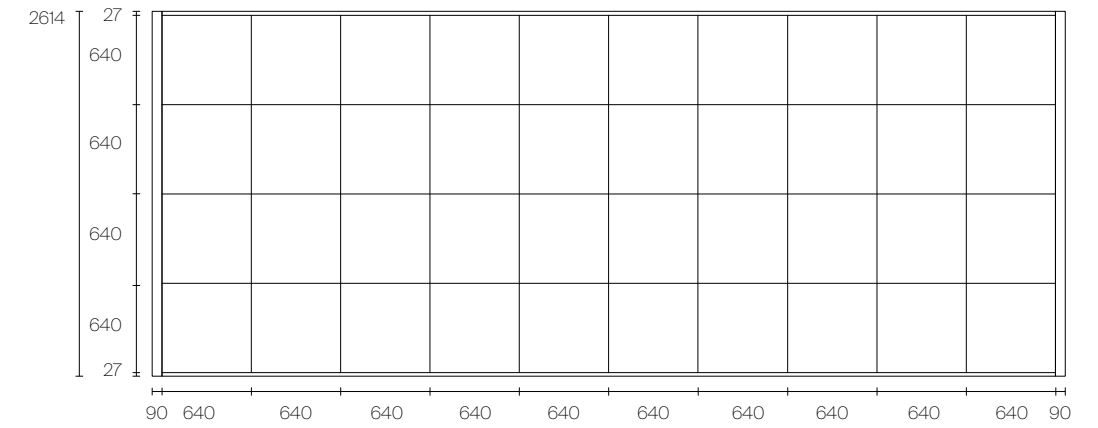
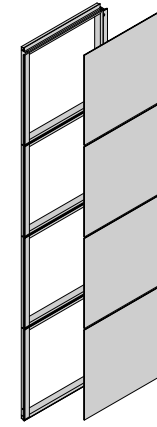

Irregular pattern panel to be equipped

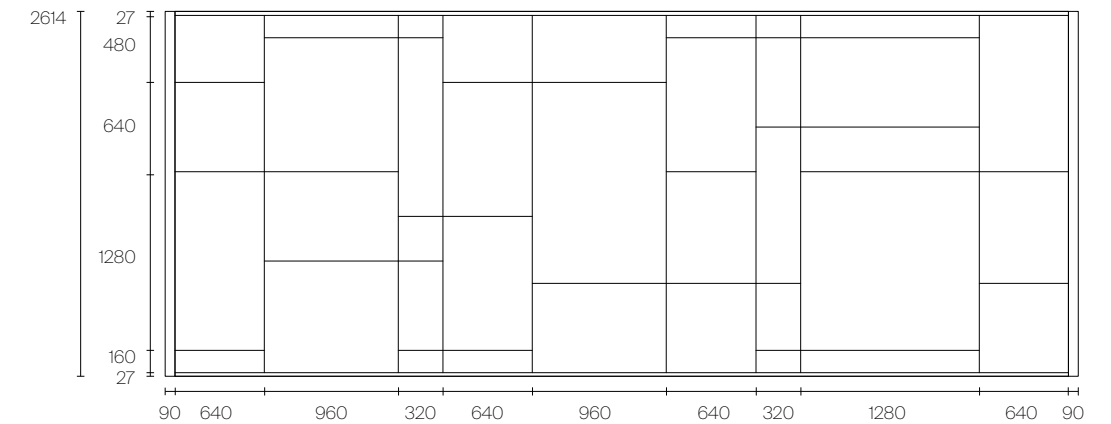
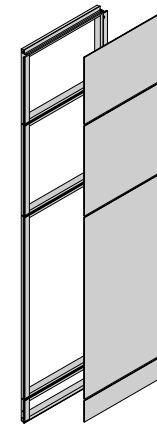



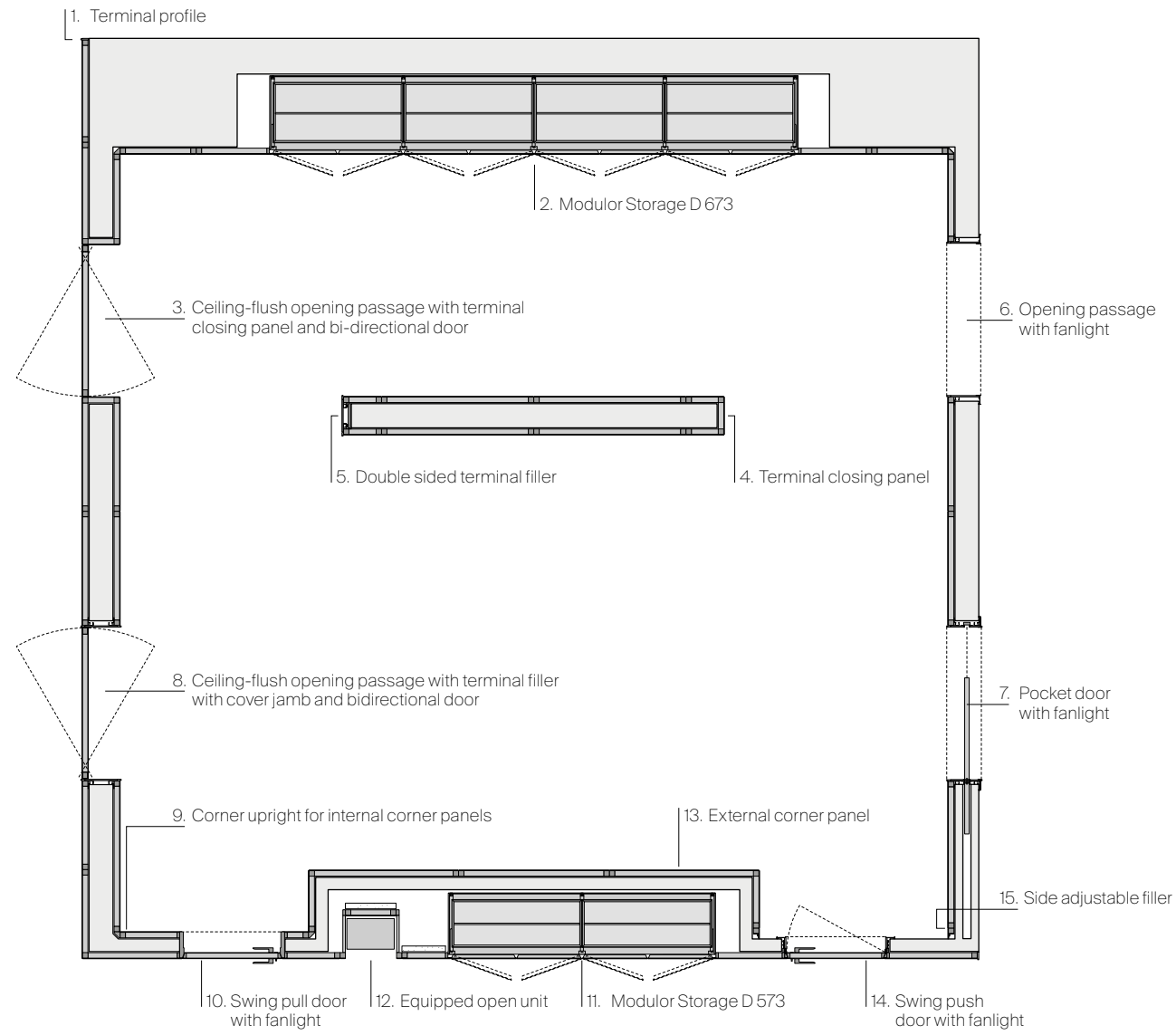

TECHNICAL DESCRIPTION

**EN** Modulor is a multi-purpose wall panelling system, modular and adjustable to different architectural needs of the residential, contract and retail projects. Emphasized by an essential design, Modulor integrates multiple possibilities: it can be equipped with suspended units, combined with pull or push opening swing doors, Radius door, Air door, pocket doors and opening passages. It also allows to completely cover the walls of a whole room.

**IT** Modulor è un sistema boiserie polifunzionale, liberamente componibile e adattabile alle diverse esigenze architettoniche del settore residenziale, contract e retail. Scandito da un design essenziale, Modulor integra molteplici varianti: può essere configurato con attrezzature sospese, combinarsi con porte a tirare, a spingere, porta Radius, porte Air, porte scorrevoli a scomparsa e passaggi. Permette inoltre di rivestire a effetto continuo le pareti di un intero ambiente.

**DE** Modulor ist ein modulares Mehrzweck Wandverkleidungssystem, das an die unterschiedlichen architektonischen Anforderungen von Wohn-, Objekt- und Einzelhandelsprojekten angepasst werden kann. Modulor zeichnet sich durch sein schlichtes Design aus und integriert mehrere Varianten: Es kann mit Hängegeräten konfiguriert werden sowie mit Türen zum Ziehen oder Drücken, Radius-Türen, Air-Türen versenkbaren Schiebetüren und Durchgängen kombiniert werden. Es erlaubt auch, die Wände eines ganzen Raumes vollständig abzudecken.

**FR** Modulor est un système de boiserie polyvalent, modulable et adaptable aux différents besoins architecturaux des secteurs résidentiel, contract et de la vente au détail. Rythmé par un design essentiel, Modulor intègre de nombreuses variantes: il peut être configuré avec des équipements suspendus, se combiner avec des portes à tirer, à pousser, porte Radius, porte Air, panneau galandage et passages. Il permet également de couvrir les murs de toute une chambre de manière continue.

**ES** Modulor es un sistema boiserie multifuncional, libremente modular y adaptable a las diferentes necesidades arquitectónicas del sector residencial, contract y retail. Marcado por un diseño esencial, Modulor integra múltiples variantes: se puede configurar con equipamiento suspendido, combinado con puertas a tirar y a empujar, puertas Radius, puertas Air, puertas correderas empotradas. También permite revestir con efecto continuo las paredes de un ambiente completo.

**RU** Modulor – это многофункциональная система стеновых панелей, свободно модулируемая и адаптируемая к различным архитектурным требованиям для жилых, торговых и офисных помещений. Благодаря минималистичному дизайну система Modulor предлагает разнообразные варианты решений: использование в сочетании с подвесным оборудованием, а также в сочетании с дверями, открывающимися внутрь и наружу, дверями Radius, дверями Air, скрытыми раздвижными дверями и проходами. Кроме того, эту систему можно использовать для облицовки стен всего помещения, создавая эффект непрерывной поверхности.

**汉语** Modulor 是一套多功能的护墙板系统，可自由组合，并满足住宅、商务和零售等不同建筑空间的需求。Modulor 以简约的设计尤为特色，并整合多样的变化形式：可配置悬挂式配件，并与推拉平开门、Radius 门、Air 门、隐藏式推拉门和通道相互搭配。同时，亦能为整个空间中的墙面创造出延伸感的效果。

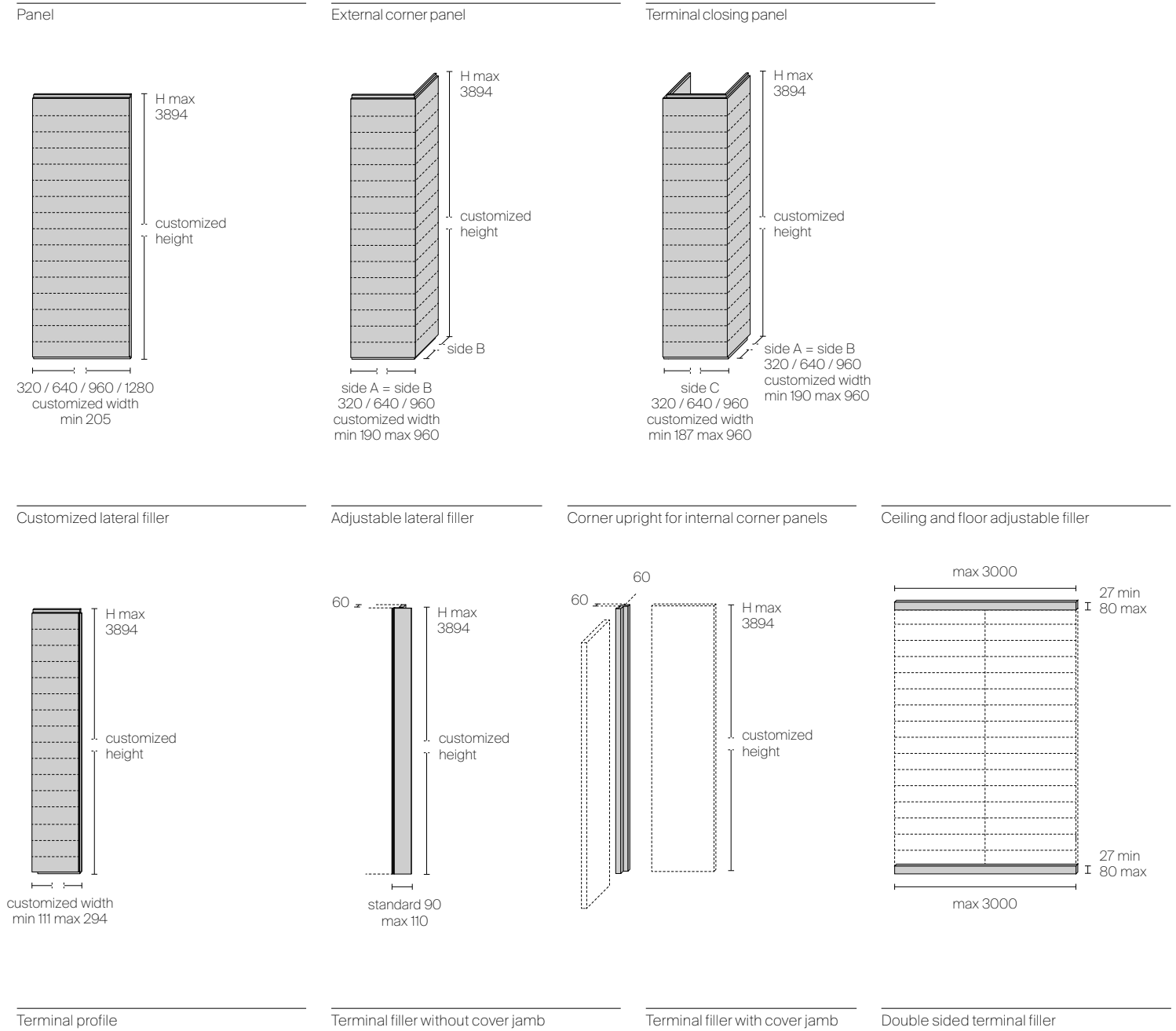

Ceiling height change with side adjustable profile

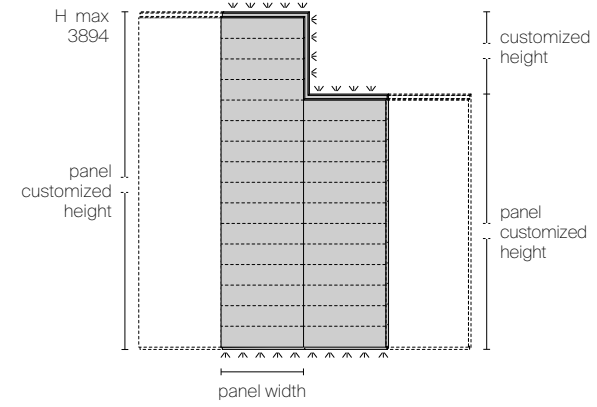

Shaped panel for sloped ceiling

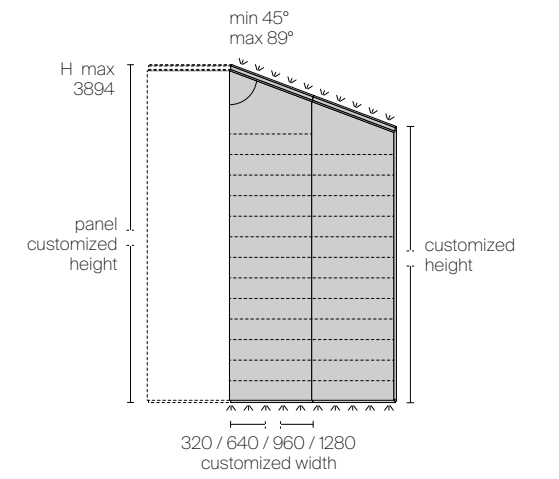

Shaped panel for stairs

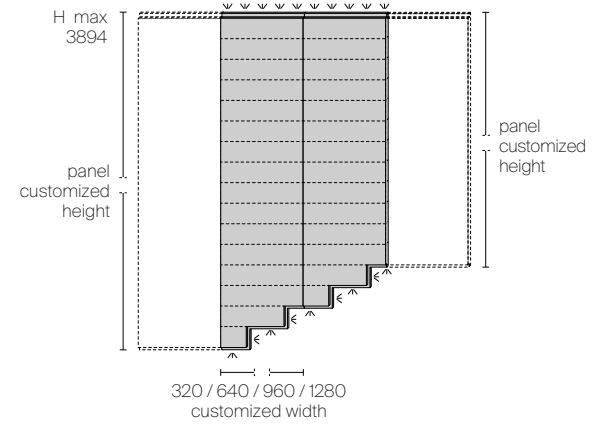

Opening passage with fanlight

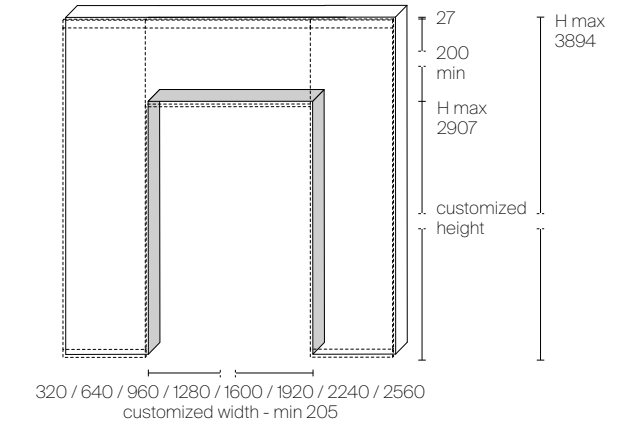





Upper and lower led lighting for Modulo panelling, 3000° Kelvin (warm light)

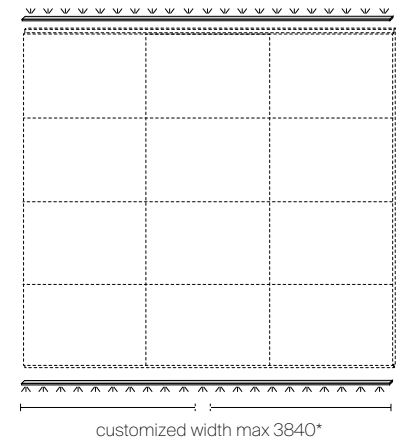

\* Led is supplied in 2 pieces for dimensions bigger than 3840 mm

Shelves with upper lighting, 3000° Kelvin (warm light)

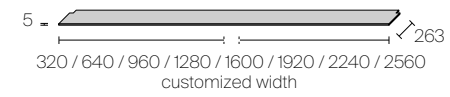

Shelf

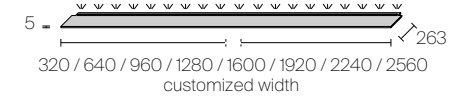

Shelf with upper lighting

Additional wall-fixing plate for Alambra

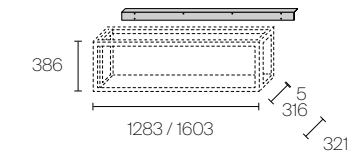

For Alambra suspended cabinet with flap door

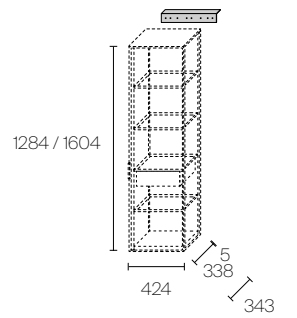

For Alambra suspended cabinet with swing door

Additional wall-fixing plate for Self, Self bold and Self plan

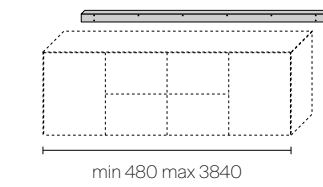

Additional wall-fixing plate for Self / Self bold suspended unit with back light

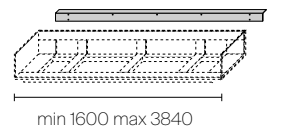

Additional wall-fixing plate for Self plan





Equipped open unit with TV set-up

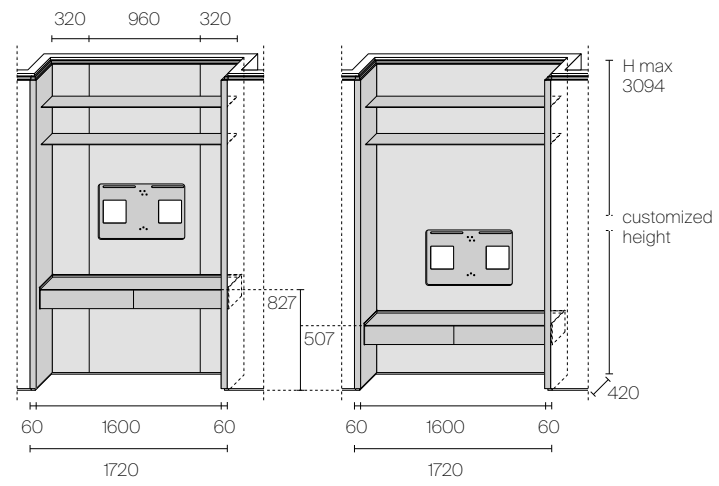

Version H 827  
Dining area, office, night area

Version H 507  
Living area

Equipped open unit with shelves

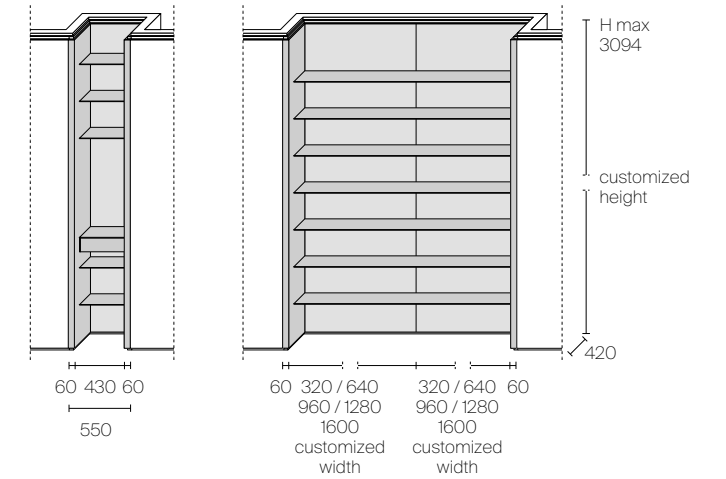

Version with shelves and  
suspended drawer

Version with shelves

Swing doors with push opening for storage unit

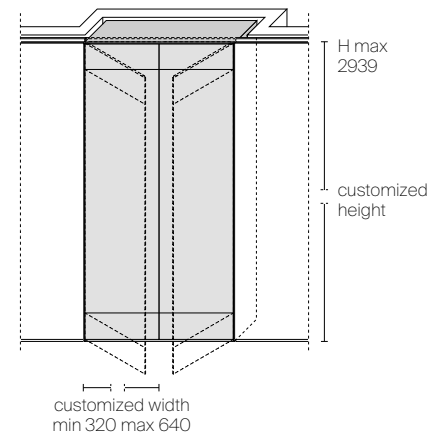

Swing doors with handle integrated in the crosspiece for storage unit

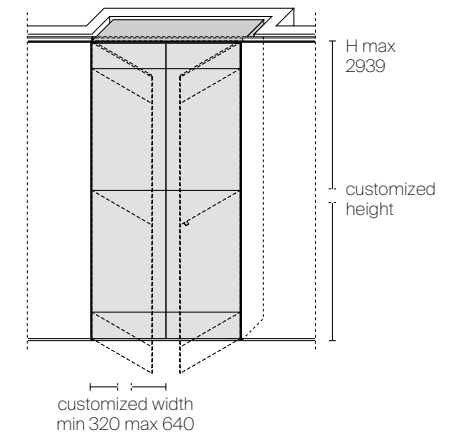



Removable cladding

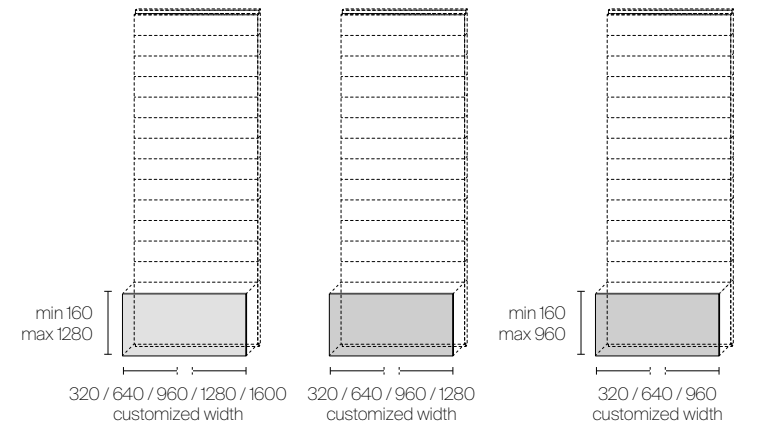

Version in glass      Version in Litech      Version in saharah wood, taiga wood, fabric, synthetic leather

Customized cut-out for set-up of switches and electrical sockets

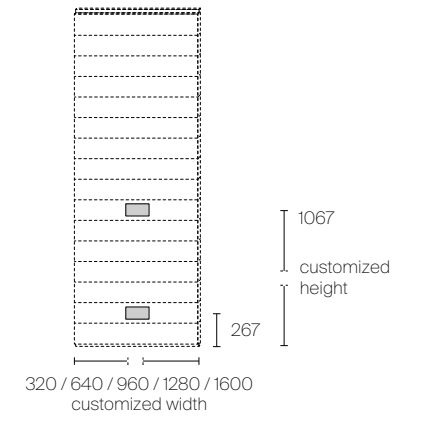
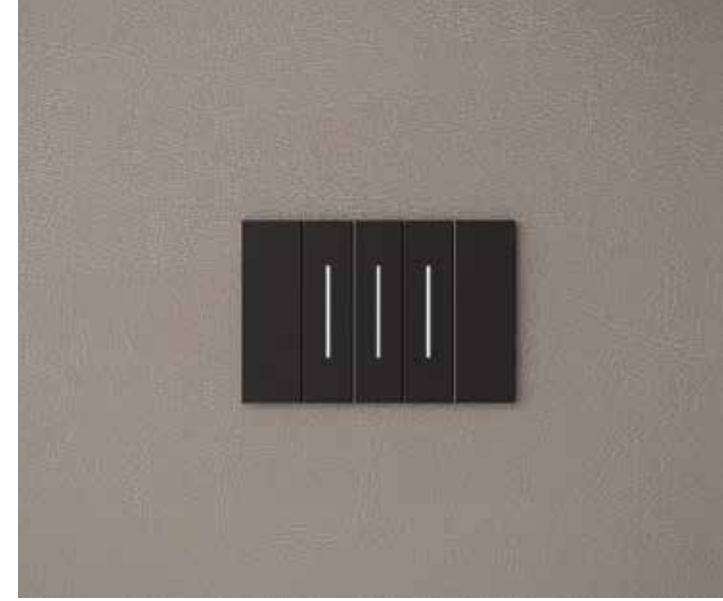

Concealed structure for suspended TV and extensible support for TV

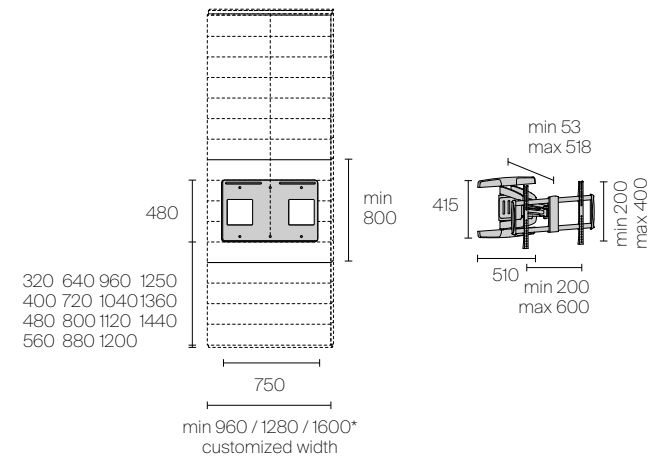

Version in saharah wood, taiga wood, fabric, synthetic leather available only in W 960 / 1280  
\*W 1600 available only for equipped open unit

Cable duct

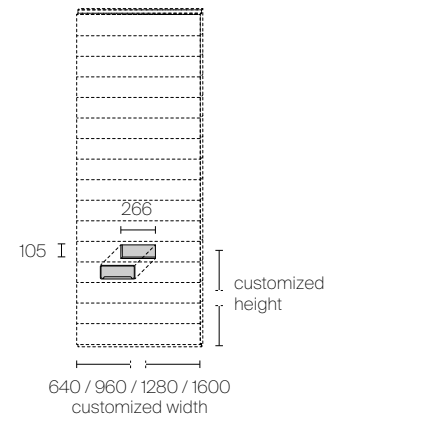
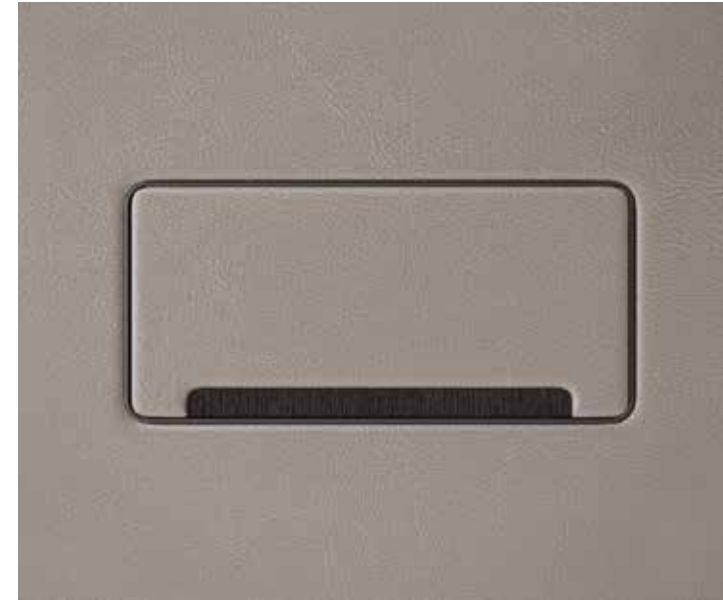





Swing door with fanlight

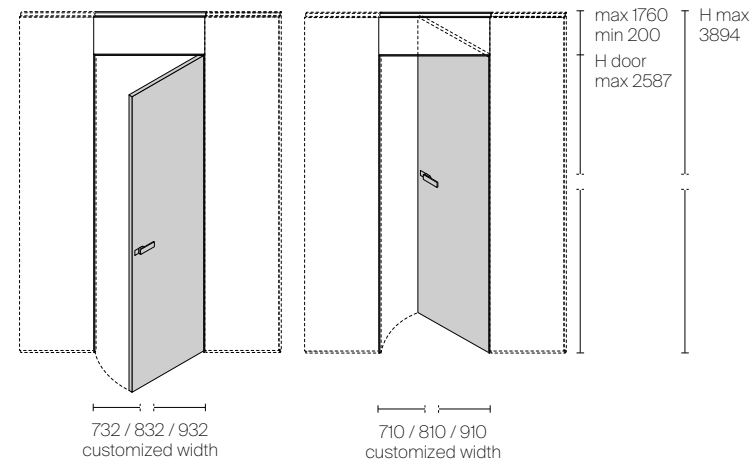

Bi-directional door

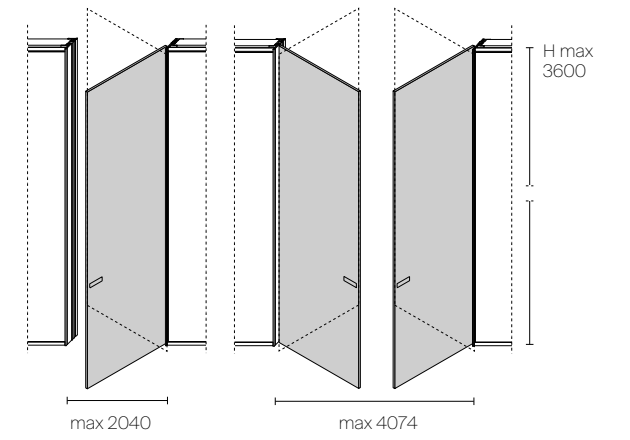

Full-height pocket door

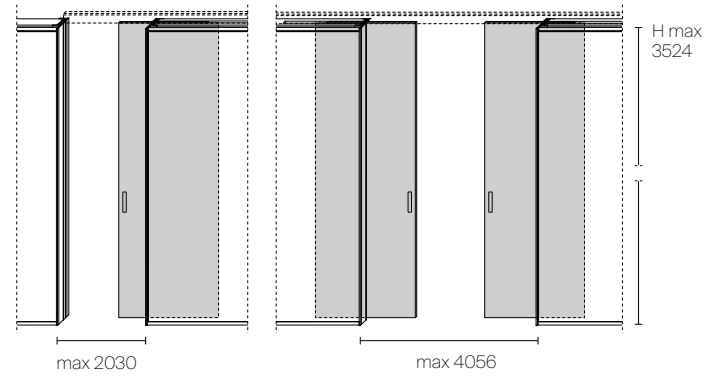

Pocket door with fanlight

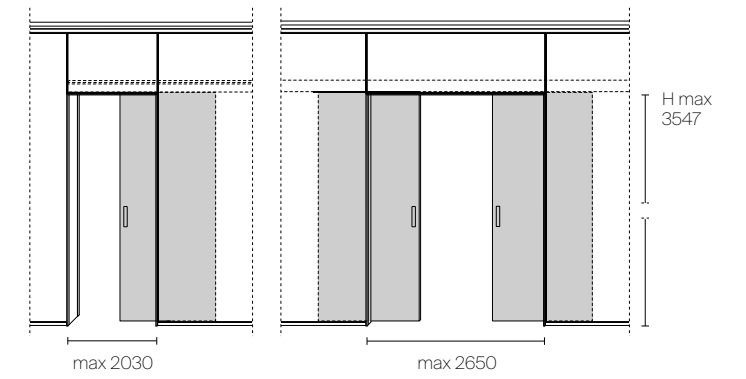



Matt glass

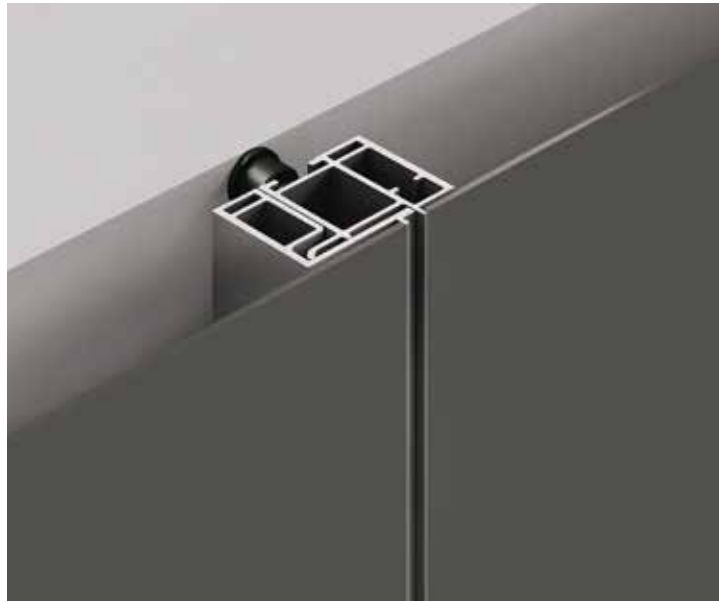

Glossy glass



Sahara wood



Taiga wood



Sahara glass



Taiga glass



Synthetic leather



Lux fabric. \*Sound-absorbing version available only for fabric panel

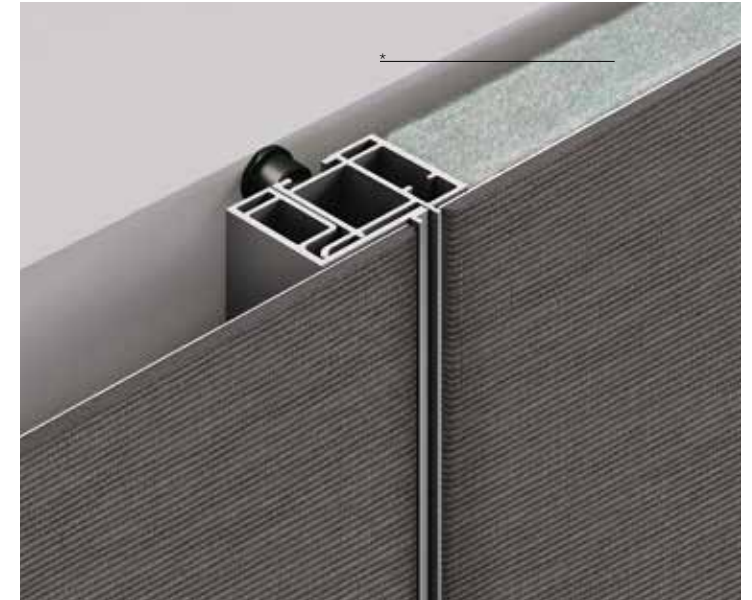

Diamante glass



Litech



Material fabric. \*Sound-absorbing version available only for fabric panel



Tech fabric. \*Sound-absorbing version available only for fabric panel

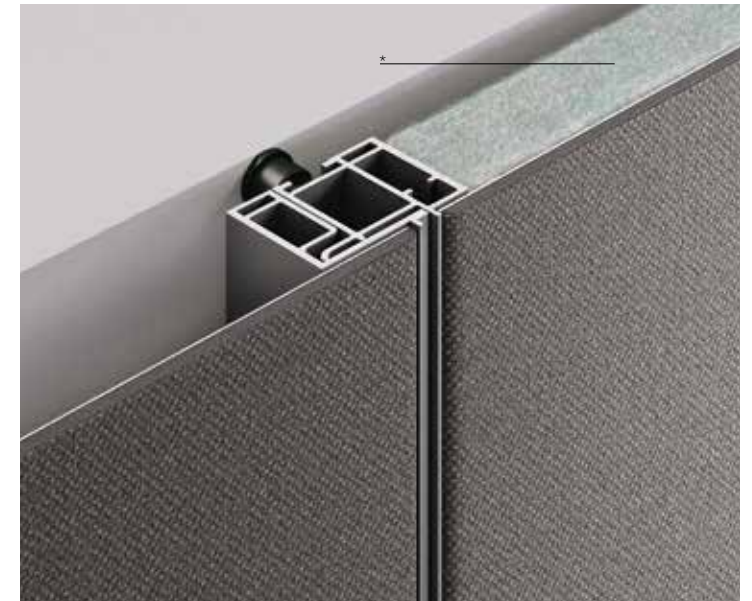



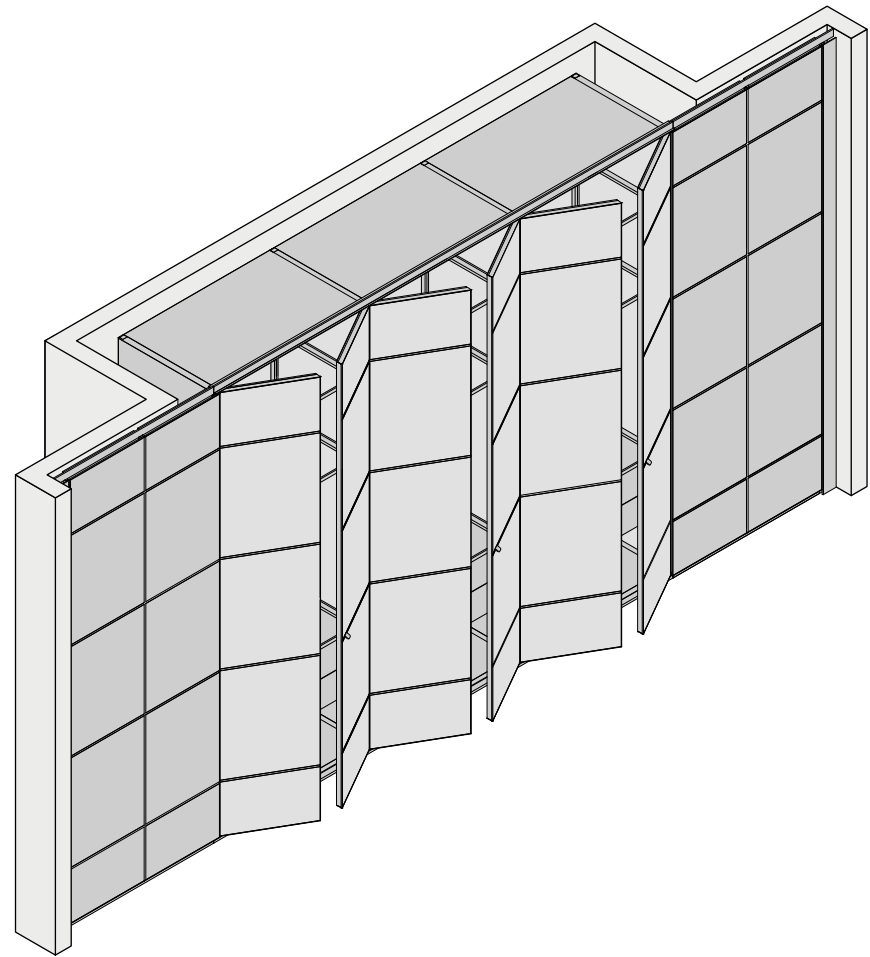

TECHNICAL DESCRIPTION

**EN** Modulor integrates a system of equipped storage units, in a solution of continuity. Designed to store and display items, it is always custom-made in width and height in order to adapt to any architectural requirements. Two versions are available: with "full height" hinged door up to a maximum of 2966 mm; with hinged door and fanlight for compositions up to 3894 mm. Available with or without horizontal crosspieces, it can be configured with doors, passages and suspended elements, as well as covering the walls to create a seamless effect. The internal accessories can be freely positioned and adjusted over time. Upper, lower and internal led lighting is optional.

**IT** Modulor integra nella boiserie un sistema di contenitori attrezzati, in una soluzione di assoluta continuità. Pensato per custodire ed esporre, è sempre realizzato su misura in larghezza e altezza per adattarsi alle esigenze architettoniche. Due le versioni disponibili: con anta battente a tutta altezza fino a un massimo di 2966 mm; con anta battente e sopralluce per composizioni che possono raggiungere i 3894 mm. Disponibile con o senza traversi orizzontali può configurarsi con porte, vani di passaggio e arredi sospesi oltre a rivestire le pareti a effetto continuo. Le attrezzature interne sono liberamente posizionabili e modificabili nel tempo. Opzionale l'illuminazione led superiore, inferiore e interna.

**DE** Modulor integriert ein System von ausgestatteten Containern in die Holzverkleidung in einer Lösung von absoluter Kontinuität. Sie wurde entworfen, um zu schützen und zu beeindrucken und wird immer in Breite und Höhe gemessen, um sich an architektonische Bedürfnisse anzupassen. Es ist in zwei Versionen erhältlich: mit voller Schwingtür bis maximal 2966 mm; mit Flügeltür und Spiegel für Kompositionen bis 3894 mm. Erhältlich mit oder ohne horizontale Balken, kann es mit Türen, Durchgängen und hängenden Möbeln konfiguriert werden und die Wände kontinuierlich abdecken. Die internen Geräte können im Laufe der Zeit frei positioniert und modifiziert werden. Optionale obere, untere und interne LED-Beleuchtung.

**FR** Modulor intègre dans la boiserie un système de compartiments équipés, dans une solution de continuité absolue. Pensé pour conserver et exposer, il est toujours réalisé sur mesure en largeur et hauteur pour s'adapter aux exigences architecturales. Il est disponible en deux versions: avec porte battante sur toute la hauteur jusqu'à un maximum de 2966 mm, avec porte battante et imposte pour des compositions pouvant aller jusqu'à 3894 mm. Disponible avec ou sans traverses horizontales il peut être configuré avec des portes, des espaces de passage et aménagements suspendus ainsi que revêtir des murs avec effet continu. Les équipements internes peuvent être librement positionnés et modifiés dans le temps. L'illumination led supérieure, inférieure et intérieure est en option.

**ES** Modulor integra en la boiserie un sistema de contenedores equipados, en una solución de continuidad absoluta. Pensado para almacenar y exponer, se realiza siempre con anchura y altura a medida para adaptarse a las necesidades arquitectónicas. Dos son las versiones disponibles: con puerta batiente de altura completa hasta un máximo de 2966 mm; con puerta batiente y panel superpuesto para composiciones que pueden alcanzar los 3894 mm. Disponible con o sin travesaños horizontales, puede configurarse con puertas, huecos de paso y muebles colgantes, así como revestir las paredes con efecto continuo. Los equipamientos internos pueden colocarse libremente y modificarse con el tiempo. La iluminación led superior, inferior e interna es opcional.

**RU** С помощью системы Modulor в стеновые панели встраивается оборудованная контейнерная система, обеспечивая абсолютную непрерывность решения. Она предназначена для хранения и экспозиции предметов и всегда выполняется по индивидуальными размерами по ширине и высоте, чтобы соответствовать требованиям архитектуры. Существует два исполнения: с распашной створкой на полную высоту, не превышающую 2966 мм, и с распашной створкой и фрамугой для композиций высотой не более 3894 мм. Изготавливается как с горизонтальными распорками, так и без них, что позволяет создавать двери, проходы и подвесную мебель, а также облицовку стен с эффектом непрерывной поверхности. Внутреннее оборудование может свободно размещаться и заменяться с течением времени. По заказу может быть выполнена верхняя, нижняя и внутренняя светодиодная подсветка.

**汉语** Modulor 将配置的柜体整合入系统之中，为一项呈现连续感的解决方案。这个设计用于妥善保存和展示物品，为满足各项建筑要求，宽度和高度皆按尺寸定制。有两种款式可供选择：全高铰链门，最大高度可达 2966 毫米；带扇形气窗和铰链门的组合，其最大高度可达 3894 毫米。提供带或不带水平横梁两种版本，除了带延伸效果覆盖的墙面之外，亦能配置各式门、通道和悬挂柜。内部配件可随时自由摆放和更动位置。有顶部、底部和内部的 LED 照明灯可供选配。

Storage unit with hinged door to the ceiling

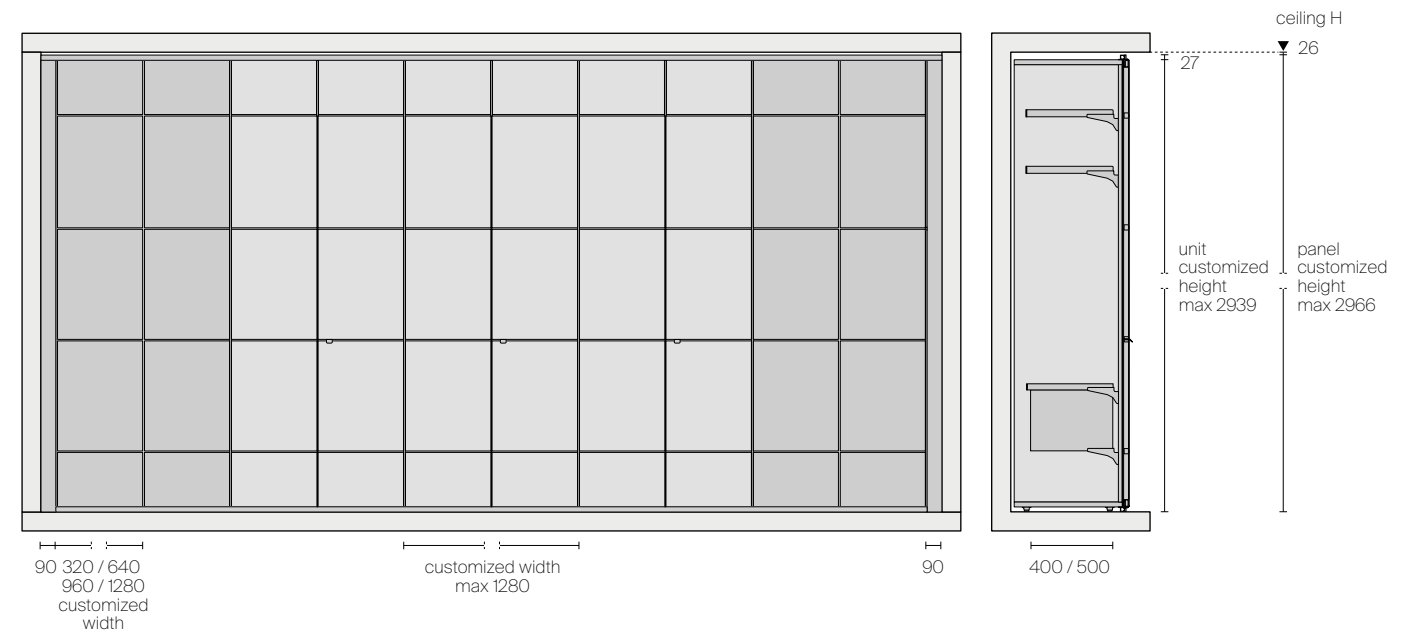

Storage unit with hinged door and fanlight

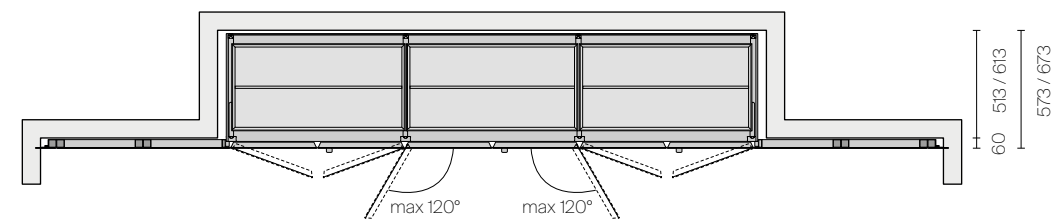
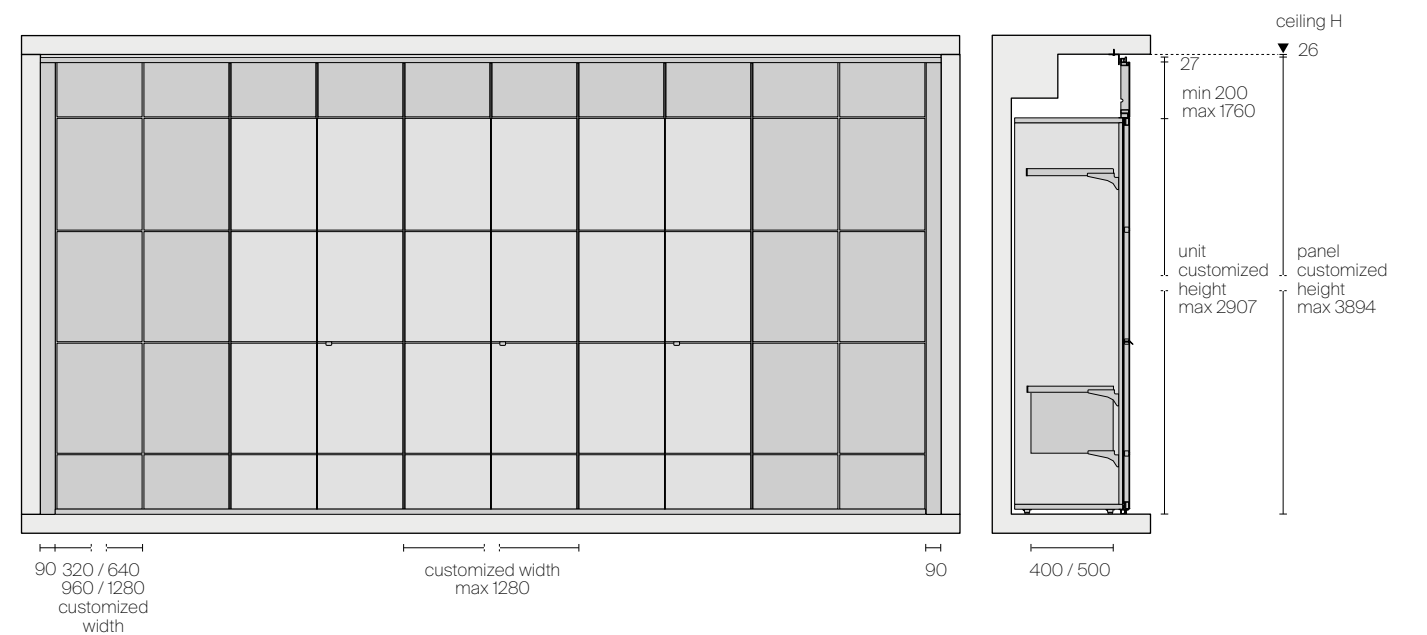

Linear composition with central storage unit

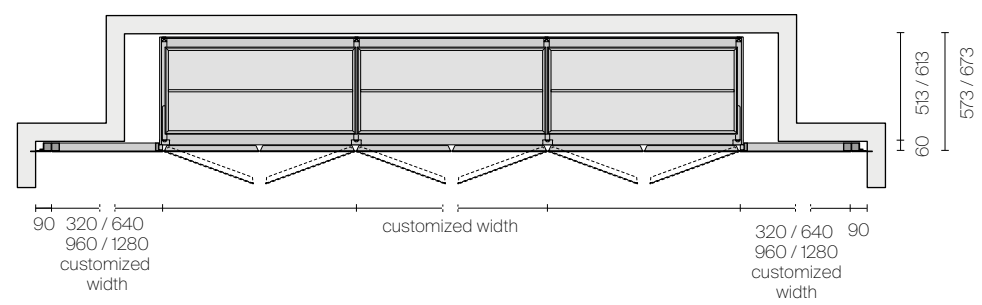

Linear composition with side storage unit

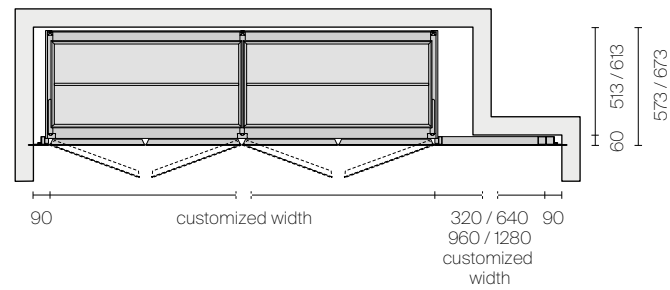

Composition with storage units and side passage opening

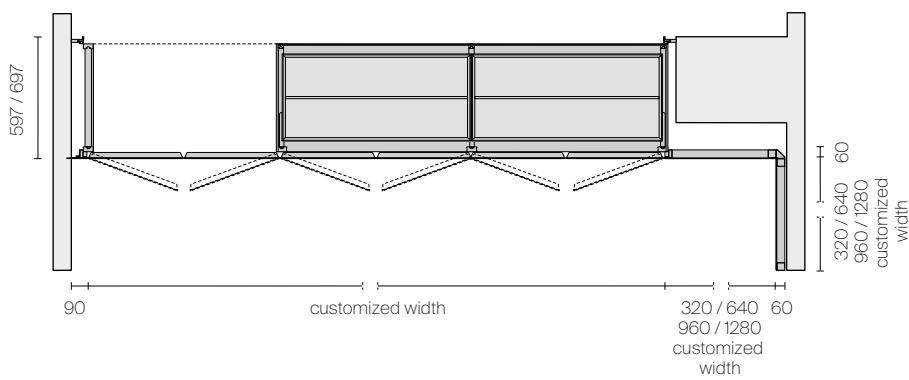

Composition with storage units and passage

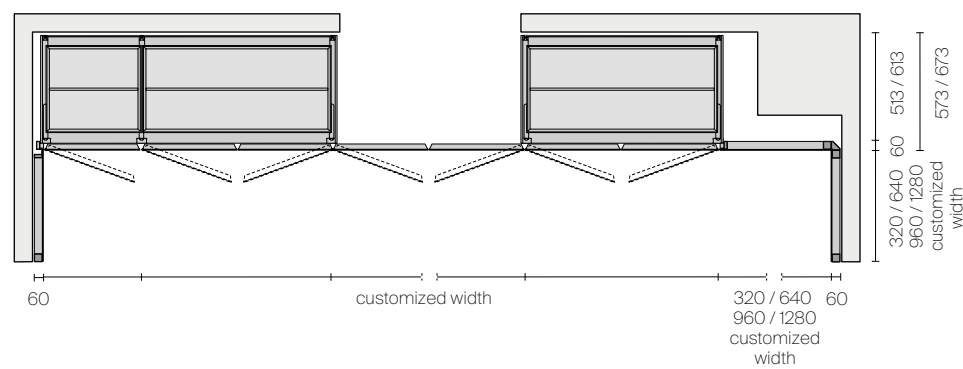

Composition with lateral storage unit

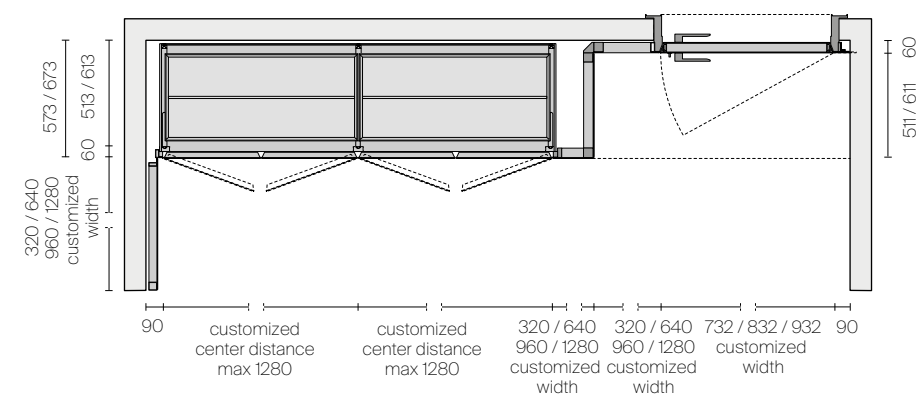

Composition with corner storage unit

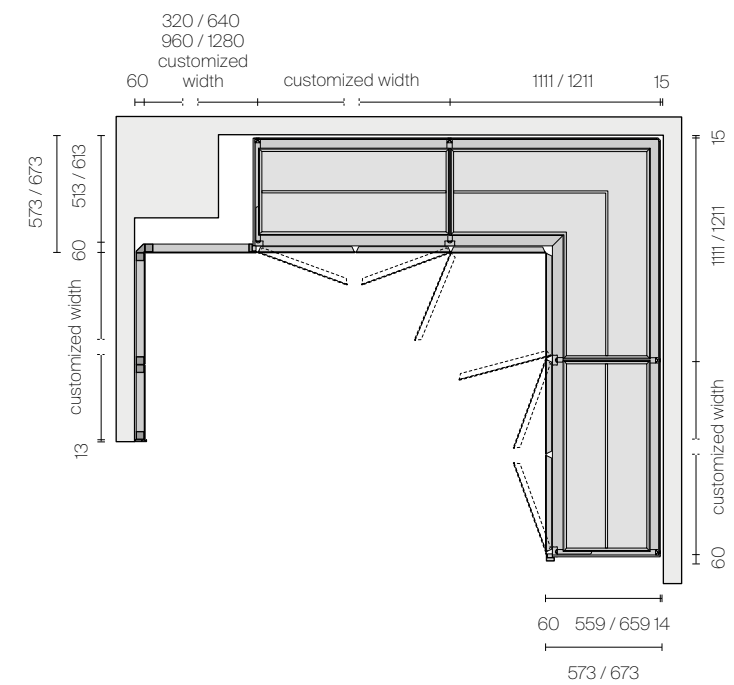



DOORS

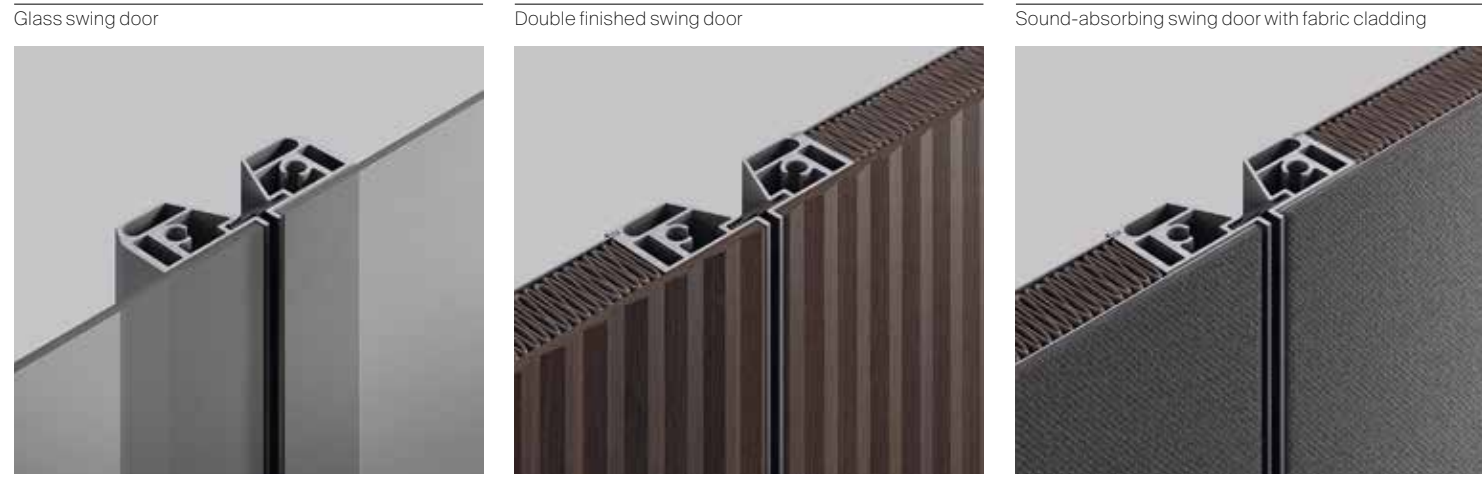

DOORS AESTHETICAL TYPOLOGIES

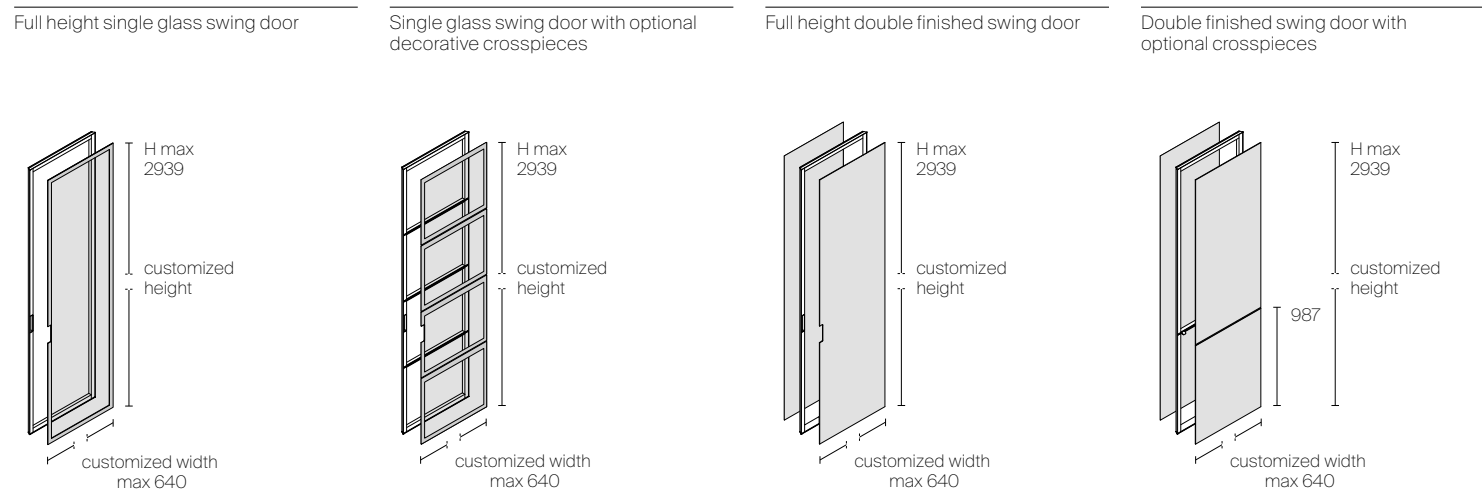

HANDLES



1. Handle 2013 in die-casting aluminium
2. Handle 2014F in die-casting aluminium with fixed lever tumbler / Handle 2014C with hook lock and key
3. Handle 2021 integrated in the crosspiece

STRUCTURAL ELEMENTS

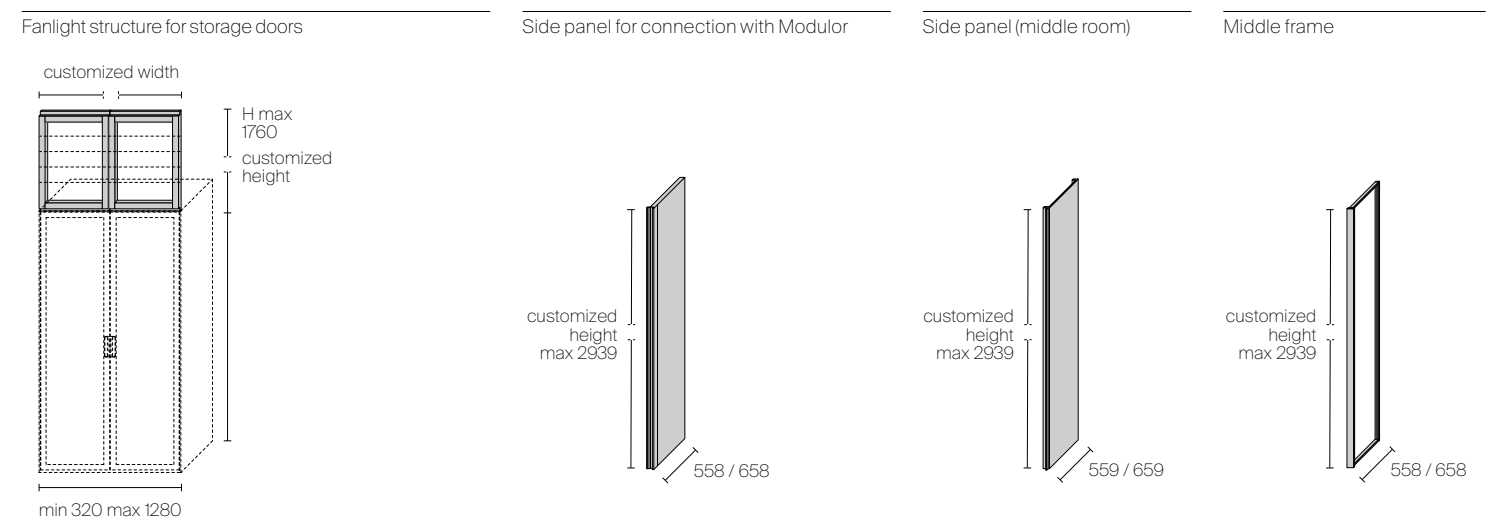
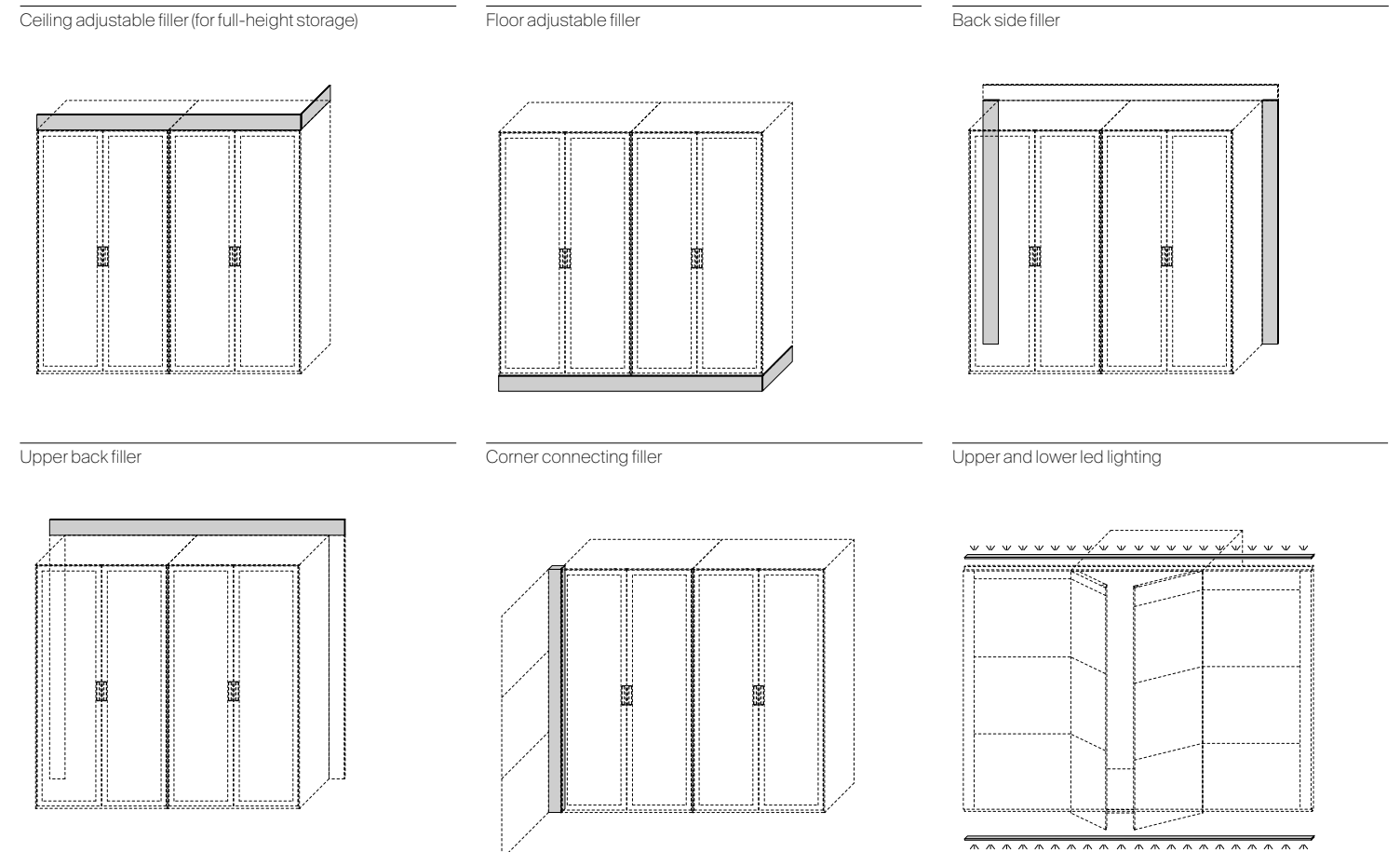
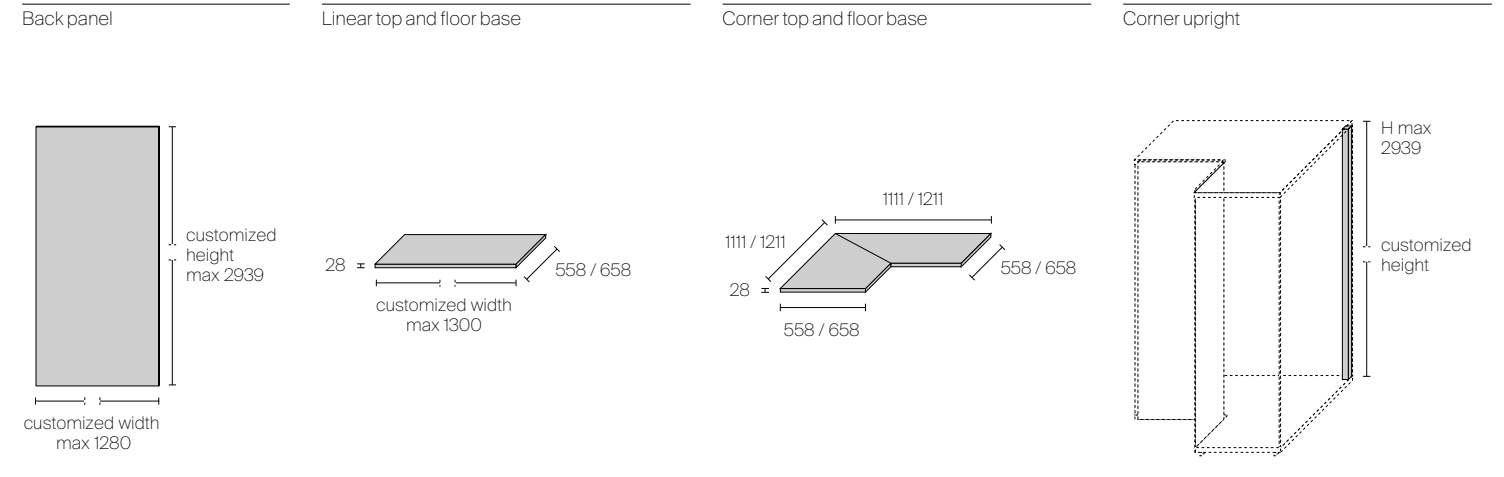

Composition example with accessories in glass, lacquered wood, synthetic leather

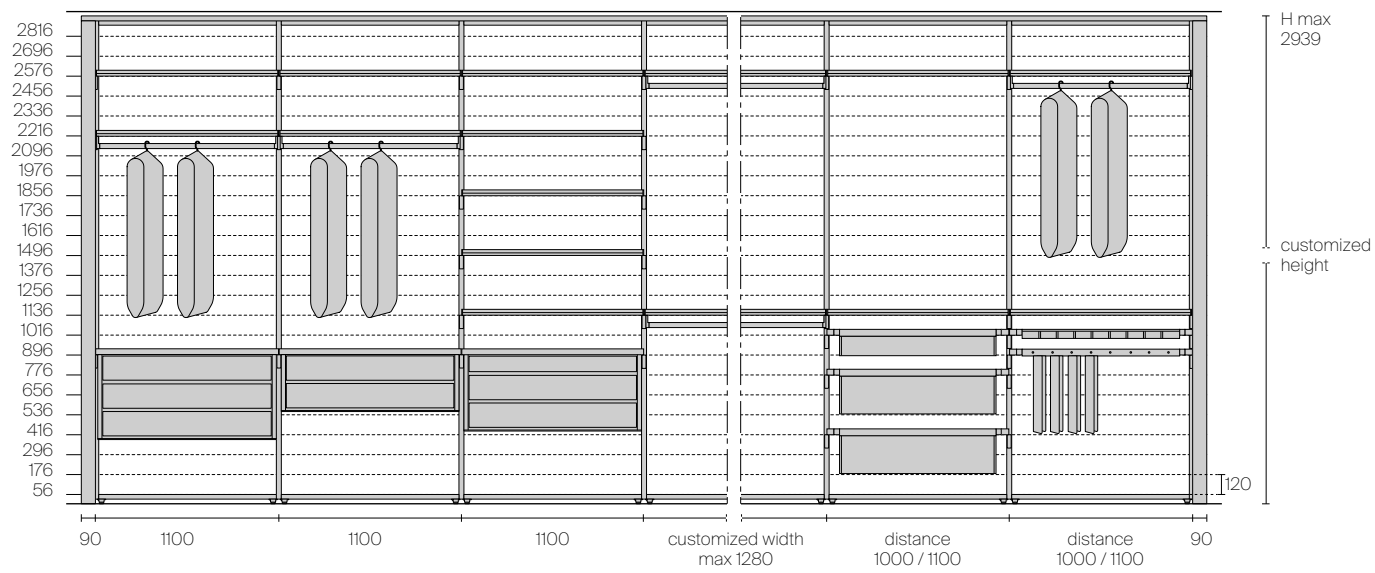

Composition example with accessories in lacquered wood and synthetic leather

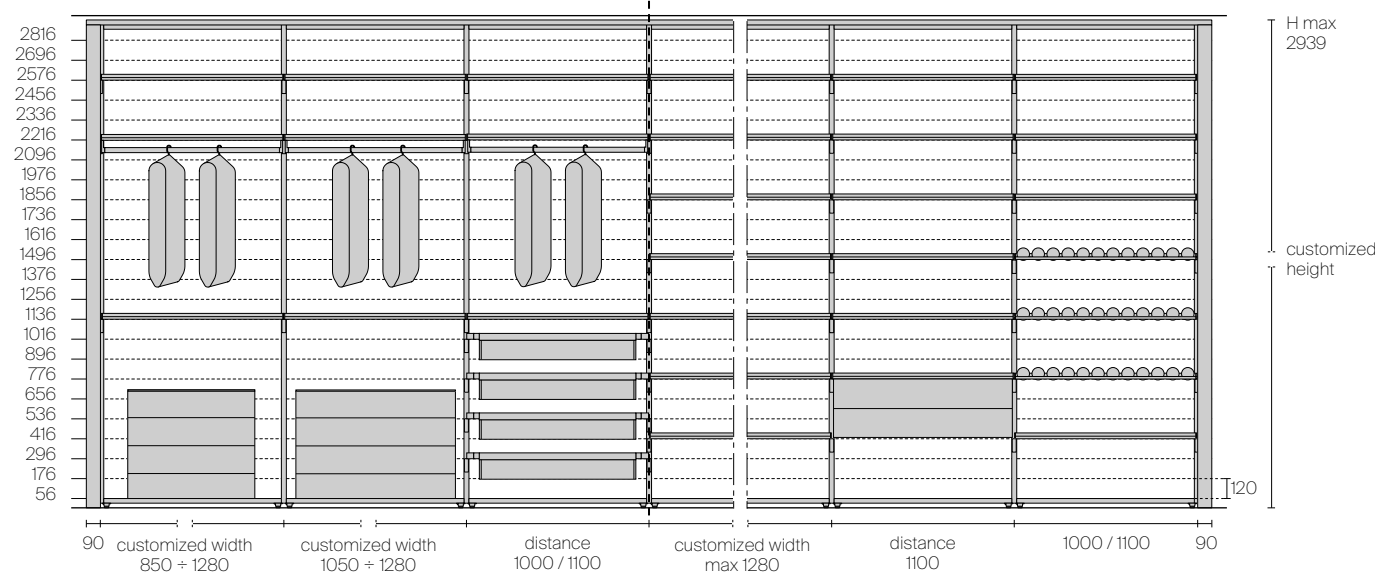

Accessories fixing system



All the elements are fixed directly to the uprights, without visible screws, and the layout can be easily modified over time.

ACCESSORIES

Shelf holder / support for suspended drawer unit

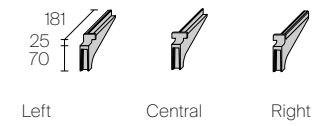

Back support for corner shelf

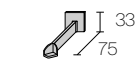

Linear melamine and glass shelf

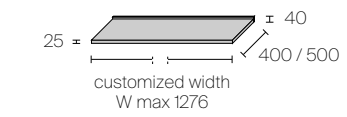

Melamine and glass corner shelf

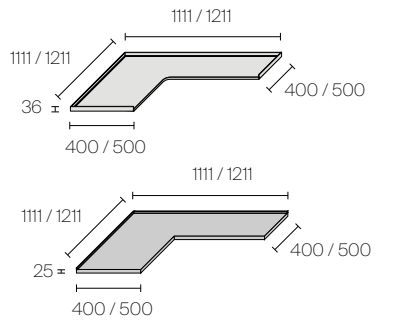

Bottle rack



Clothes-hanger for shelf or top

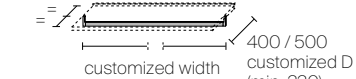

Clothes-hanger for corner shelf or top

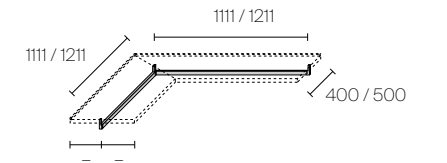

Suspended drawer unit in melamine

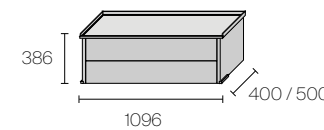

Drawer unit on floor base in melamine with 3 drawers

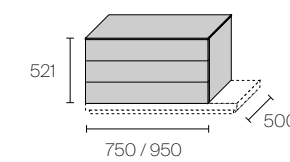

Drawer unit on floor base in melamine with 4 drawers

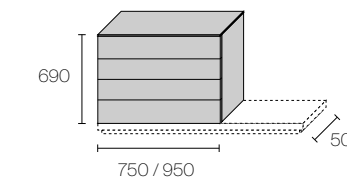

Drawer unit on floor base in lacquered glass with 4 drawers

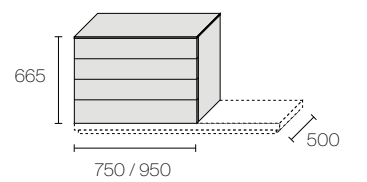

Suspended drawer unit in lacquered wood

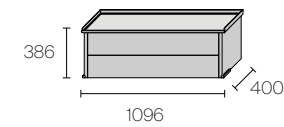

Synthetic leather mat for internal lining

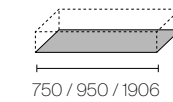

Optional melamine top with lining in synthetic leather

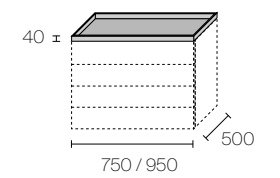
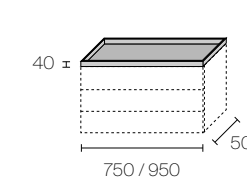





1



2



3



4



1. Transparent glass top, 3 drawers with glass front. Synthetic leather internal drawer cladding
2. Top, fronts and internal drawer cladding in synthetic leather
3. Transparent glass top, 1 drawer with glass front, 2 drawers with open fronts. Fabric internal drawer cladding
4. Transparent glass top, 1 drawer with glass front, 2 drawers with aluminium fronts. Synthetic leather internal drawer cladding

H 377 with 2 drawers

2 aluminium fronts

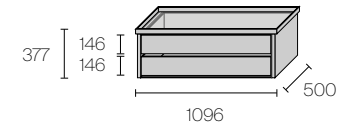

2 glass fronts

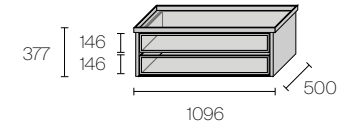

2 synthetic leather fronts

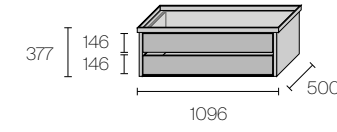

2 open fronts

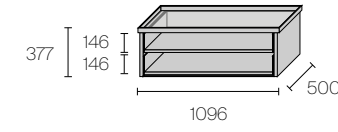

1 glass front, 1 aluminium front

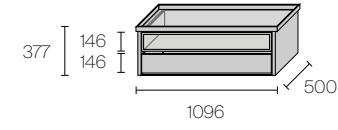

1 glass front, 1 open front

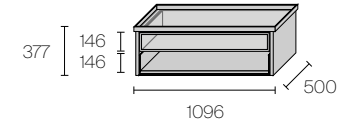

1 glass front, 1 synthetic leather front

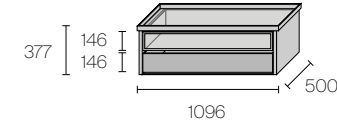

H 492 with 3 drawers

3 aluminium fronts

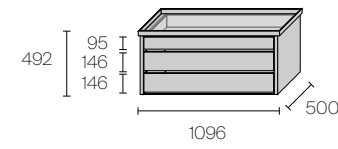

3 glass fronts

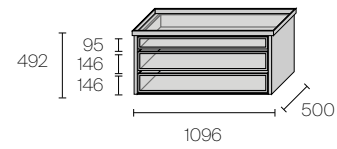

3 synthetic leather fronts

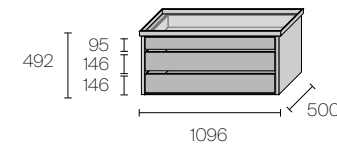

1 glass front, 2 aluminium fronts

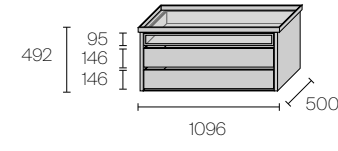

1 glass front, 2 open fronts

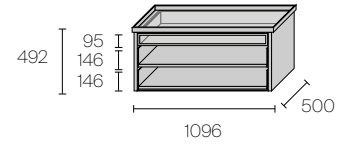

1 glass front, 2 synthetic leather fronts

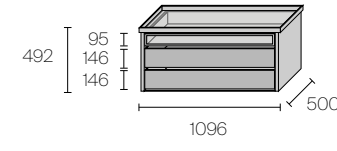

H 543 with 3 drawers

3 aluminium fronts

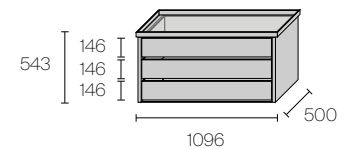

3 glass fronts

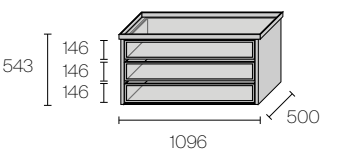

3 synthetic leather fronts

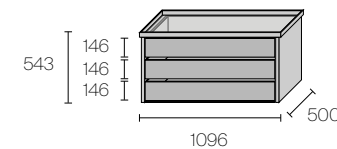

3 open fronts

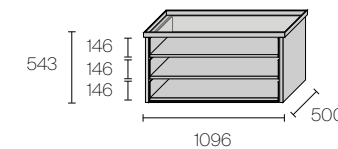

1 glass front, 2 aluminium fronts

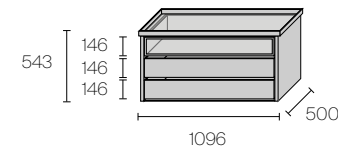

1 glass front, 2 open fronts

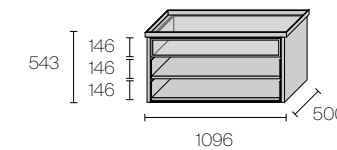

1 glass front, 2 synthetic leather fronts

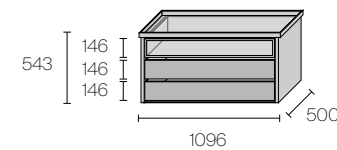



1



2

1. Melamine shelf
2. Melamine drawer unit for floor base
3. Pull-out shelf with tray in synthetic leather
4. Pull-out shelf with tie rack in synthetic leather
5. Pull-out shelf with shoes rack in synthetic leather



3



4



5



1



2

1. Glass shelf covered with synthetic leather
2. Suspended drawer unit in melamine with synthetic leather top
3. Pull-out shelf with organizer in lacquered wood and tray in synthetic leather
4. Pull-out shelf with trousers rack and belt tray in synthetic leather
5. Small pull-out tray in synthetic leather
6. Big pull-out tray in synthetic leather



3



4



5



6





1



2



3



4



5



6

1. Proposal B with accessories inside the organizer:  
3 veneered organizers, 1 organizer with double partition, 1 watch holder, 2 concave boxes
2. Proposal B with accessories outside the organizer:  
3 veneered organizers, 1 organizer with double partition, 1 watch holder
3. Proposal A with accessories outside the organizer:  
3 veneered organizers, 2 organizers with double partition, 1 concave box, 1 box with jewels slot
4. Proposal A with accessories inside the organizer:  
3 veneered organizers, 2 organizers with double partition, 1 concave box, 1 box with jewels slot
5. Synthetic leather box
6. Synthetic leather tray

Pull-out shelf with organizer tray in lacquered wood and tray in synthetic leather

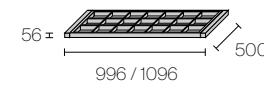

Pull-out shelf with tie rack in synthetic leather

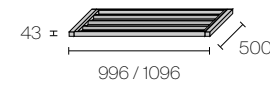

Pull-out shelf with trousers rack and belt tray in synthetic leather with 11/13 extractable rods

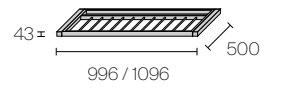

Pull-out small tray in synthetic leather

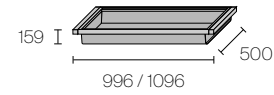

Pull-out big tray in synthetic leather

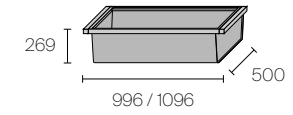

Pull-out shelf with shoes rack in synthetic leather

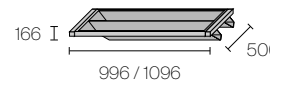

Pull-out shelf with tray in synthetic leather

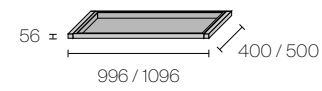

Veneered organizer

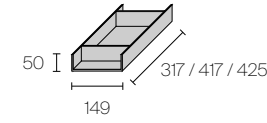

Organizer with double partition in synthetic leather

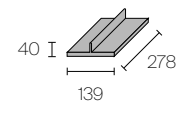

Watch holder in synthetic leather

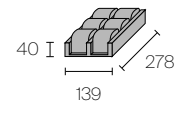

Box with concave box and jewels slots in synthetic leather

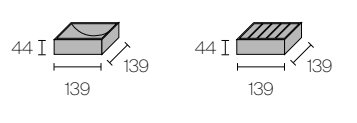

Synthetic leather box

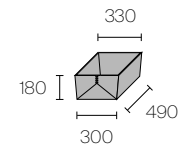

Synthetic leather tray

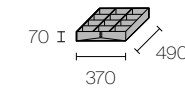

Wooden clothes hanger



Panel and door cladding and double finished swing door



Single glass swing door

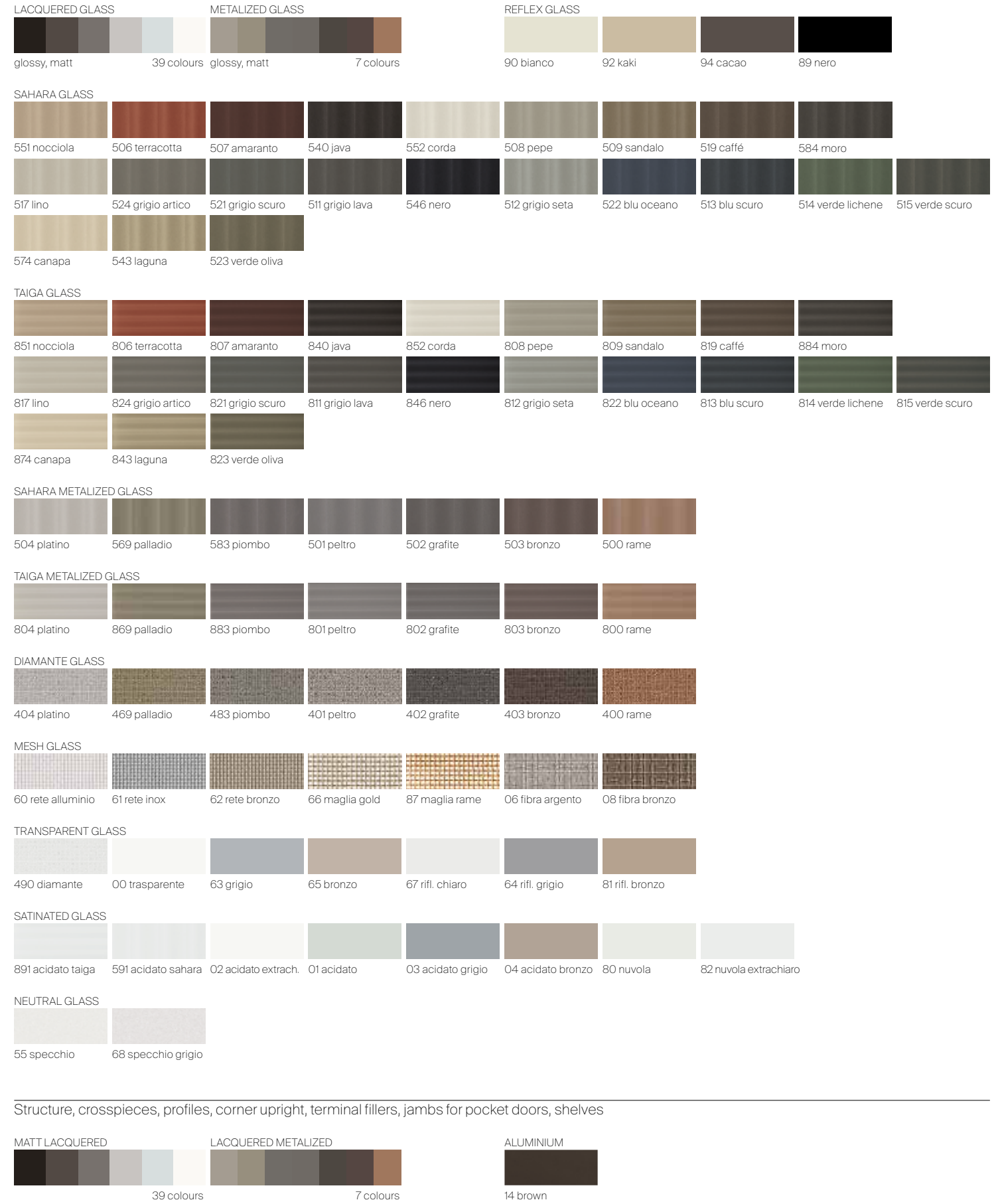

Structure, crosspieces, profiles, corner upright, terminal fillers, jambs for pocket doors, shelves

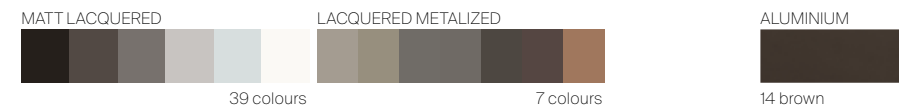



Storage side panels

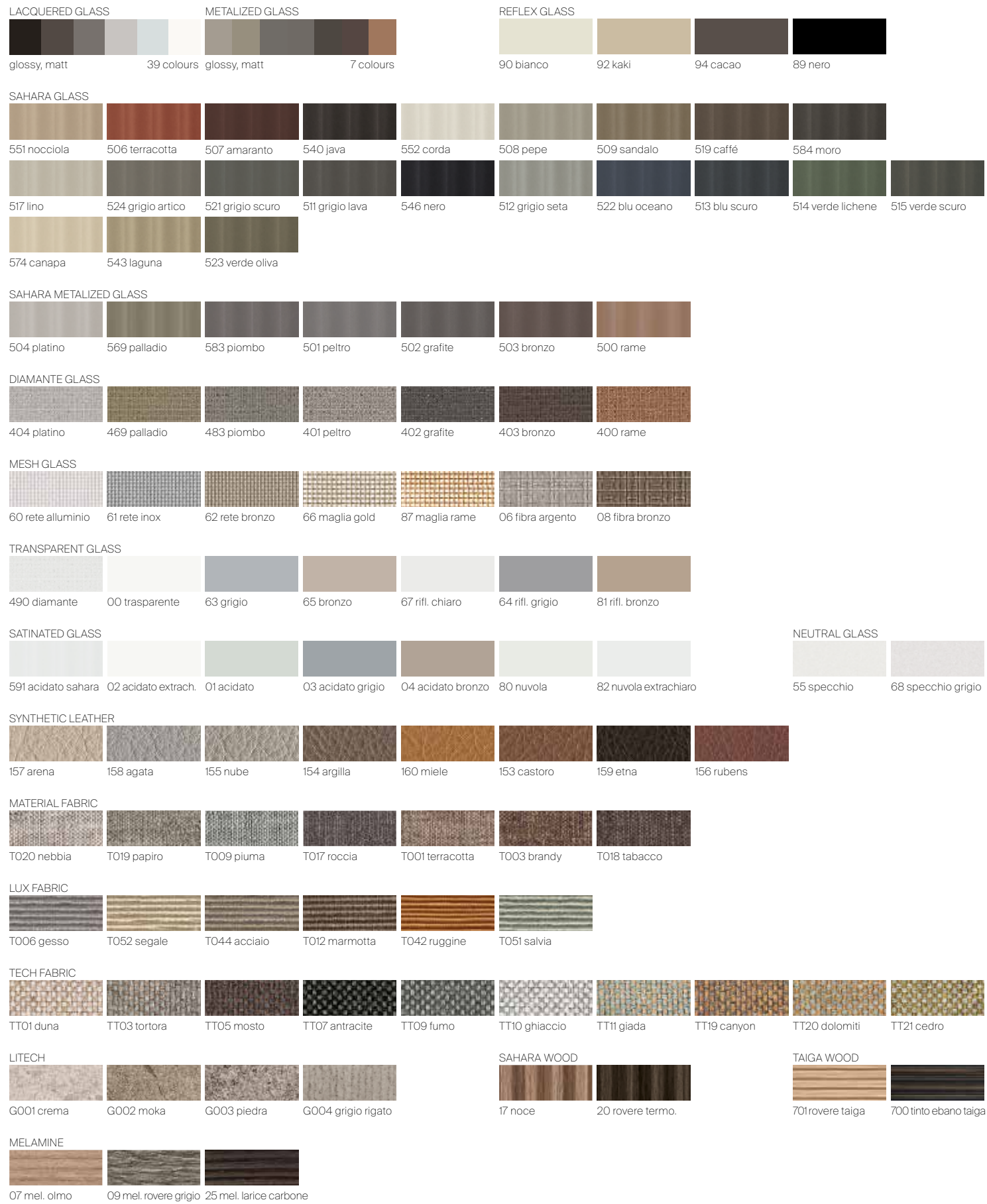

Storage floor base and top

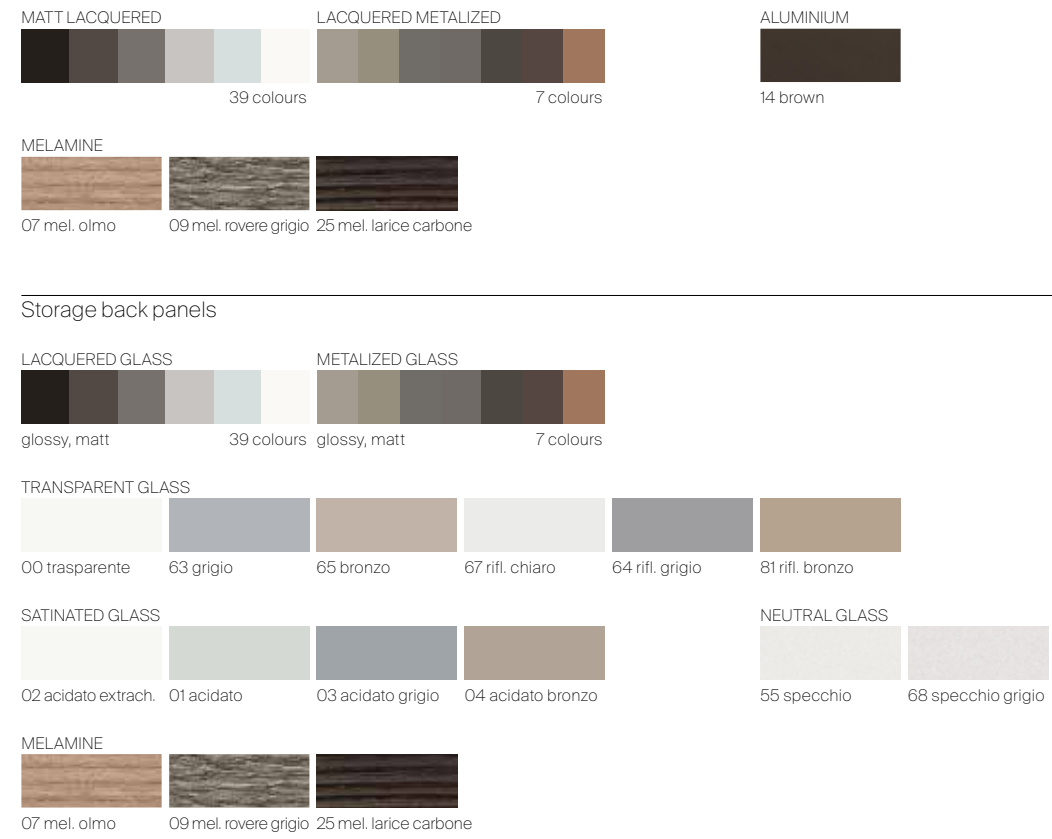

Storage back panels

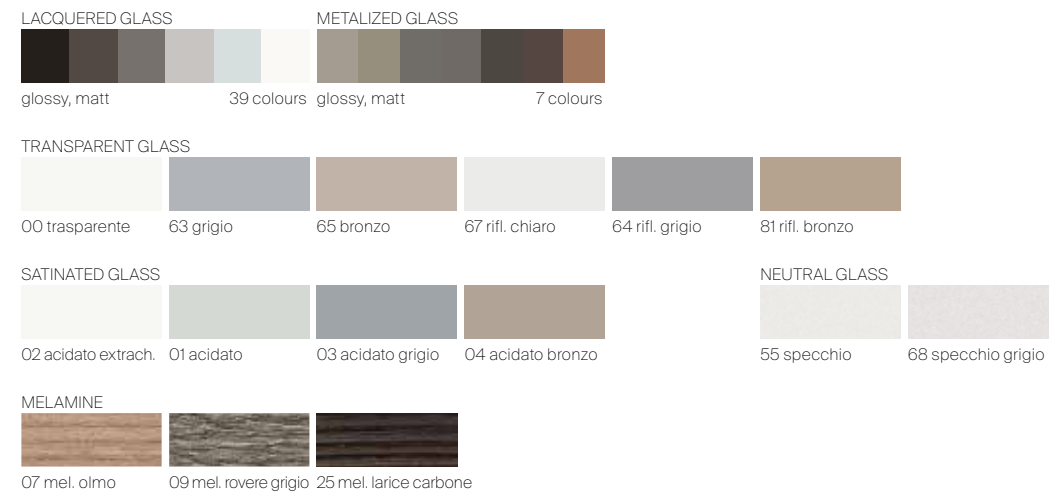

FINISHINGS

Internal shelf

TRANSPARENT GLASS

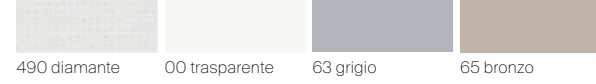

SATINATED GLASS

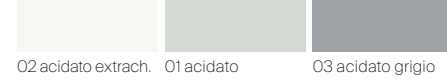

SYNTHETIC LEATHER

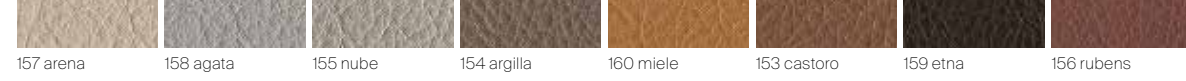

MELAMINE



Bottle rack

ALUMINIUM

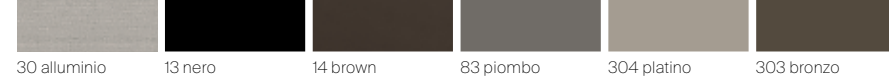

MELAMINE



Drawer units for floor base or on wheels

LACQUERED GLASS METALIZED GLASS



DIAMANTE GLASS



MELAMINE



Pull-out shelf, clothes-hanger, mat for internal lining

SYNTHETIC LEATHER

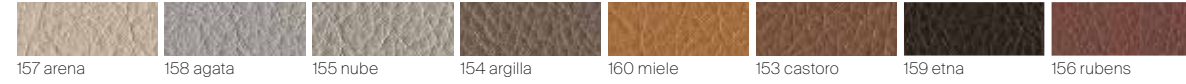

Suspended drawer units with aluminium drawers

MATT LACQUERED



LACQUERED METALIZED



ALUMINIUM

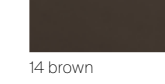

TRANSPARENT GLASS



SYNTHETIC LEATHER

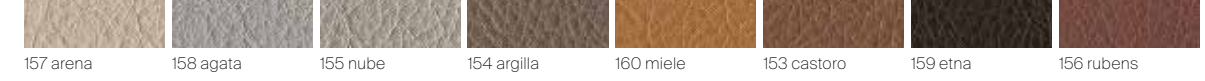

Drawer internal cladding

SYNTHETIC LEATHER

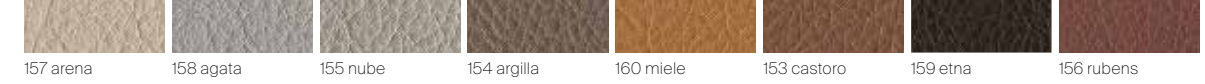

MATERIAL FABRIC



LUX FABRIC

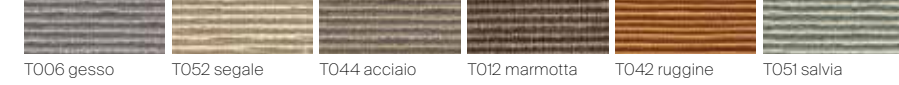

TECH FABRIC



Suspended drawer units in lacquered wood or melamine

MATT LACQUERED



LACQUERED METALIZED



ALUMINIUM

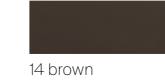

MELAMINE



Internal drawer unit

INTERNAL MELAMINE





QUALITY AS THE MAIN PURPOSE, ALWAYS AND IN EVERY ASPECT, WITH THIS MISSION RIMADESIO IS CONSTANTLY SEARCHING FOR SOLUTIONS TO IMPROVE ITS OWN ECOLOGICAL STANDARDS.

OBJECTIVE OBTAINED THANKS TO THE USE OF PRECIOUS AND RECYCLABLE MATERIALS, TO THE ABSENCE OF SUBSTANCES THAT CAN BE TOXIC TO HUMANS OR HARMFUL TO THE ENVIRONMENT IN EVERY PHASE OF THE PRODUCTIVE PROCESS, TO THE USE OF TECHNOLOGY AND EVOLVED MACHINERY, POWERED BY CLEAN ENERGY DERIVED FROM PHOTOVOLTAIC SYSTEMS, INSTALLED ON THE GIUSSANO HEADQUARTERS ROOF.

ALUMINIUM, GLASS, WOOD: FULLY RECYCLABLE AND PARTLY ALREADY RECYCLED MATERIALS.

PROOFS OF A REINFORCED GREEN DNA AND WIDE COHERENCE, SIGNALS OF A CONTINUOUS RESEARCH AND A GLANCE TOWARDS THE FUTURE, THAT TAKES SHAPE IN THE TECHNOLOGICAL INNOVATION OF SYSTEMS, DOORS AND FURNITURE, MADE WITH THE AWARENESS OF WANTING TO ENTRUST HUMANS ONLY WITH HIGH VALUE-ADDED ACTIVITIES.

# EXCELLENCE SUSTAINABILITY PROJECT

IT Perseguire la qualità, sempre, sotto tutti gli aspetti. Con questa mission Rimadesio ricerca costantemente soluzioni volte a migliorare i propri standard qualitativi ecologici. Obiettivo ottenuto sinergicamente, grazie all'utilizzo di materiali preziosi e riciclabili, all'assenza di sostanze tossiche per l'uomo e nocive per l'ambiente in ogni fase del processo produttivo, all'impiego di tecnologie e macchinari evoluti alimentati con energia pulita proveniente da impianti fotovoltaici, installati sulla copertura dell'headquarter di Giussano. Alluminio, vetro, legno, materiali totalmente riciclabili e in parte già riciclati, ma anche le vernici prive di solventi di Ecoloursystem e i sistemi di imballaggio ecologici. Testimonianze di un dna green consolidato e di una coerenza trasversale, segnali di una continua attività di ricerca e di uno sguardo sempre proteso al futuro che si declina nell'innovazione tecnologica di sistemi, porte ed arredi, realizzati con la consapevolezza di voler affidare all'uomo solo attività dall'alto valore aggiunto.

DE Stets um Qualität bemüht, und zwar in allen Bereichen. Mit dieser Mission im Blick sucht Rimadesio laufend nach Lösungen, um seine ökologischen Qualitätsstandards zu verbessern. Dieses Ziel wurde dank der Verwendung wertvoller und wiederverwertbarer Materialien, dem Verzicht auf für den Menschen giftige und umweltschädliche Stoffe in jeder Phase des Produktionsprozesses und dem Einsatz fortschrittlicher Technologien und Maschinen, die mit sauberer Energie aus den auf dem Dach des Giussano-Hauptsitzes installierten Photovoltaikanlagen betrieben werden, synergetisch erreicht. Aluminium, Glas, Holz, vollständig recycelbare und teilweise bereits recycelte Materialien, aber auch die Lösungsmittelfreien Farben von Ecoloursystem und umweltfreundliche Verpackungssysteme. Ein Zeugnis einer fundierten grünen DNA und einer transversalen Kohärenz, Zeichen einer kontinuierlichen Forschungstätigkeit und eines stets in die Zukunft gerichteten Blicks, der sich in der technologischen Innovation von Systemen, Türen und Einrichtungsgegenständen ausdrückt, die in dem Bewusstsein realisiert werden, den Menschen nur Tätigkeiten mit hohem Mehrwert anzuvertrauen.

FR Poursuivre la qualité, toujours, et à tous les égards. Avec cette mission Rimadesio recherche constamment de solutions au fin d'améliorer ses normes de qualité écologique. Objectif atteint, grâce à l'utilisation de matériaux précieux et recyclables, l'absence à chaque étape de la production de substances toxiques nocives pour l'homme et l'environnement, l'utilisation de technologies et des machines avancées alimentées par l'énergie solaire après l'installation sur le toit de l'usine à Giussano de systèmes photovoltaïques. Aluminium, verre, bois, des matériaux entièrement recyclables et déjà en partie recyclés, mais aussi peinture Ecoloursystem sans solvants et systèmes d'emballage respectueux de l'environnement. Témoignages d'un adn "vert" consolidé et d'une cohérence transversale, signes de recherche continue et d'une tendance à regarder en avant, qui correspond bien à l'innovation technologique des systèmes, des portes et des meubles, réalisés avec la conscience que l'apport de l'homme dans la production ne peut qu'avoir un valeur ajoutée.

ES Perseguir la calidad, siempre, en todos los aspectos. Con esta misión Rimadesio busca constantemente soluciones destinadas a mejorar sus estándares de calidad ecológica. Objetivo conseguido sinérgicamente, gracias al uso de materiales preciosos y reciclables, a la ausencia de sustancias tóxicas para los seres humanos y nocivas para el medio ambiente en cada etapa del proceso de producción, al uso de tecnologías y máquinas avanzadas alimentadas por energía limpia a partir de sistemas fotovoltaicos, instalados en la cobertura del headquarter de Giussano. Aluminio, cristal, madera, materiales completamente reciclables y, en parte, ya reciclados, sino también las pinturas Ecoloursystem libres de disolventes y los sistemas de embalaje ecológicos. Testimonios de un adn green consolidado y una coherencia transversal, señales de una continua investigación y de una vista siempre tendida al futuro que se declina en la innovación tecnológica de sistemas, puertas y muebles, realizados con el conocimiento que desea confiar al hombre sólo actividades de alto valor añadido.

RU Обеспечение качества всегда и во всем. И, в том числе, для достижения этой цели Компания Rimadesio находится в постоянном поиске решений, направленных на улучшение экологических стандартов качества. Эта цель была достигнута благодаря использованию на каждом этапе производственного процесса ценных материалов, пригодных для вторичной переработки, отсутствию токсичных для человека и вредных для окружающей среды веществ, а также благодаря внедрению передовых технологий и оборудования, работающего на чистой энергии от фотоэлектрических систем, установленных на крыше штаб-квартиры компании в г. Джуссано. Компания использует такие материалы, как алюминий, стекло, дерево – полностью перерабатываемые и уже частично переработанные материалы, краски Ecoloursystem, не содержащие растворителей, а также экологически упаковку. Свидетельство консолидированной экологичности и непрерывной последовательности, исследовательской деятельности и взгляда, всегда устремленного в будущее, что выражается в технологических инновациях систем, дверей и мебели, произведенных с осознанием того, что человеку стоит поручать только деятельность с высокой добавленной стоимостью.

汉语 始终至终追求全方位的卓越品质。Rimadesio 肩负使命，不断探索精进生态质量标准的解决方案。品牌目标之达成有赖于珍贵的可回收材料，该材料在所有制造阶段皆不会产生危害人体和环境之有毒物质，同时结合业界前沿的技术以及先进机械装置；而位于朱塞诺 (Giussano) 品牌总部建筑屋顶上的光伏发电设备为上述之机械装置供给干净的能源。除了可完全回收和已部分回收的铝材、玻璃、木材等材料之外，还有环保色彩系统 (Ecoloursystem) 的无溶剂涂料和生态环保型包装。深植的绿色 DNA、跨领域的协同性、持续的研究工作以及具前瞻性的未来展望皆体现在家具系统、各式门类 and 家具配件的技术创新上，其本着信赖人类才能胜任高附加价值活动的意念研发而成。

## GUIDE TO RIMADESIO QUALITY

### TEMPERED GLASSES

Single tempered glasses cooked at a temperature of 650 °C. Mechanical resistance 5 times superior in comparison to a normal glass. In case of breaking it crumbles in harmless tiny fragments. In accordance with the UNI EN 12150, UNI 7697 and UNI EN 12600 rules with reference to the security of glasses for decoration purposes.

### LAMINATED GLASSES

Double glasses. Between the two glasses a thin plastic film is inserted. Transparent and invisible, it perfectly sticks to both surfaces. Both surfaces are perfectly smooth.Resistance to breaking in accordance with the UNI EN ISO 12543, UNI 7697 and UNI EN 12600 rules. The plastic film witholds the fragments in case of breaking.

### GLASS WITH METAL NET AND MESH

Double laminated glasses. Between the two extra-clear glasses and two thin plastic films a micronet fabric is inserted. Through a sophisticated process a metal layer is applied on the fabric, thus creating a characteristic effect of semi transparency. The reflections of the light on the surface of the metallic net are provided by using an extra-clear float glass, which allows maximum transparency and high light transmissions, thanks to the low content of iron oxides. Following the process of hot stratification, the fabric might show minor wave effect, which give the material its characteristic materic and natural look.

ECOLORSYSTEM LACQUERED GLASSES Ecolorsystem is the name that distinguishes the exclusive Rimadesio lacquered glass collection in glossy and matt finishing. Ecological colours produced using exclusively water paints of latest generation, cooked at 110° C. A production technology in the area of glass, with a fully robotised in-house plant that ensures very high quality results and a low environmental impact work cycle. Corrosion resistance conforms to the UNI EN ISO 9227 standard. Temperature fluctuation resistance conforms to the UNI 9429 standard. The colour is inside the double glass, safe from stains, dust and humidity. The thickness of the glass creates an exclusive "depth" effect.

### VETRI TEMPERATI

Vetri singoli, sottoposti al trattamento della tempra ovvero ad una cottura alla temperatura di 650 °C. Resistenza meccanica di 5 volte superiore rispetto ad un vetro normale. In caso di rottura si sbriciola in minuti frammenti inoffensivi. Conformi alle norme UNI EN 12150, UNI 7697 e UNI EN 12600 in materia di sicurezza per i vetri d'arredamento.

### VETRI STRATIFICATI

Vetri doppi. Fra i due vetri è inserita una sottile pellicola di materiale plastico, trasparente ed invisibile, che aderisce completamente alle due superfici. Entrambe le superfici sono perfettamente lisce. Resistenza alla rottura conforme alle norme UNI EN ISO 12543, UNI 7697 e UNI EN 12600. La pellicola di materiale plastico in caso di rottura trattiene i frammenti.

### VETRI STRATIFICATI RETE, MAGLIA E FIBRA

Vetri doppi stratificati. Tra i due vetri extra-chiari e le due sottili pellicole in materiale plastico, è inserito un tessuto in microrete sul quale, tramite un sofisticato processo di materizzazione, viene depositato uno strato metallico che crea un caratteristico effetto di semitrasparenza. Le riflessioni della luce sulla superficie della rete metallizzata sono ottenute con l'utilizzo del vetro float extrachiaro che, grazie al basso contenuto di ossidi di ferro, garantisce la massima trasparenza e un'elevata trasmissione luminosa. Il tessuto, a seguito del processo di stratifica a caldo, può presentare delle leggere ondulazioni che conferiscono al materiale il suo caratteristico aspetto materico e naturale.

### VETRI LACCATI ECOLORSYSTEM

Ecolorsystem è la denominazione che contraddistingue l'esclusiva collezione di vetri laccati Rimadesio, disponibili in finitura lucida e opaca. Colori ecologici perché prodotti utilizzando esclusivamente vernici all'acqua di ultima generazione, con cottura a 110°C. Una tecnologia produttiva all'avanguardia nell'ambito del vetro, con impianti interni totalmente robotizzati che assicurano risultati di altissima qualità e un ciclo di lavorazione a basso impatto ambientale. Resistenza alla corrosione conforme alla norma UNI EN ISO 9227. Resistenza agli sbalzi di temperatura conforme alla norma UNI 9429. Colori inalterabili nel tempo perché applicati sulla superficie interna del vetro, al sicuro da macchie, polvere e umidità. Lo spessore del vetro crea un esclusivo effetto di "profondità".

### TEMPERIERTES GLAS

Einzelgläser, die einer Härtingsbehandlung oder einer Kochtemperatur von 650 °C unterzogen wurden. Mechanische Beständigkeit 5 mal höher als bei normalem Glas. Im Bruchfall zerbröckeln harmlose Bruchstücke in Minuten. Entspricht den Normen UNI EN 12150, UNI 7697 und UNI EN 12600 für die Sicherheit von Möbelgläser.

### SCHICHTGLAS

Doppelgläser. Zwischen den beiden Gläsern befindet sich ein dünner Film aus transparentem und unsichtbarem Kunststoff, der vollständig an den beiden Oberflächen haftet. Beide Oberflächen sind komplett glatt. Die Bruchfestigkeit entspricht den Normen UNI EN ISO 12543, UNI 7697 und UNI EN 12600. Die Kunststofffolie bewahrt im Bruchfall die Bruchstücke.

### SCHICHTGLAS MIT METALLNETZ, MASCHENGEWEBE UND FASER

Hierbei handelt es sich um Doppel-schichtgläser. Zwischen den zwei Extralight-Glasscheiben und den beiden unsichtbaren Plastikfolien wird ein Metallnetz deposited auf ce tissu, créant un effet caractéristique translucide. Les reflets de la lumière sur la surface de la maille métallique sont obtenus avec l'utilisation du verre float extra clair, qui, grâce à un faible teneur de oxydes de fer, permet un maximum de transparence et de transmission de la lumière. Suite au procédé de stratification à chaud, le tissu peut présenter de petites ondulations, qui apportent au matériau son aspect caractéristique et naturel.

### LACKIERTE GLÄSER ECOLORSYSTEM

Ecolorsystem ist der Name der lackierten Glas-Kollektion von Rimadesio in der glänzend und matte Ausführung verfügbar. Absolut oekologische Farben, da die modernsten Lackierungen, auf Wasser-Basis, an einer Temperatur von 110° gekocht werden. Eine fortschrittliche Produktionstechnik in der Glasverarbeitung auf einer vollautomatisierten Anlage, die Ergebnisse höchster Qualität und gleichzeitig umweltfreundliche Verarbeitungsverfahren gewährleistet. Korrosion-sprüfung gemäß Bestimmung UNI EN ISO 9227. Temperaturwechselprüfung gemäß Bestimmung UNI 9429. Unverändliche Farben da die Farbung sich im Innen des Doppelglases, geschützt vor Staub, Kratzen und Feuchtigkeit, befindet. Die Dicke des Glases erzeugt eine einzigartige Tiefwirkung.

### VERRES TREMPÉS

Verres simples, soumis au traitement de trempe et donc à une température de cuisson de 650 °C. Résistance mécanique 5 fois supérieure à celle du verre normal. En cas de rupture, des fragments inoffensifs s'effritent en quelques minutes. Conforme aux normes UNI EN 12150, UNI 7697 et UNI EN 12600 pour la sécurité des verres pour les meubles.

### VERRES STRATIFIÉS

Double verres. Entre les deux verres se trouve une fine pellicule de matière plastique, transparente et invisible, qui adhère complètement aux deux surfaces. Les deux surfaces sont parfaitement lisses. La résistance aux ruptures est conforme aux normes UNI EN ISO 12543, UNI 7697 et UNI EN 12600. La pellicule retient les fragments en cas de rupture.

### VERRE FEUILLETÉ AVEC NET, MAILLE ET FIBRA

Double verre stratifié. Entre les deux verres extra clair et les deux films fins de matière plastique un tissu en micro maille est ajouté. A travers un procédé avancé de materisation un couche métallique est déposé sur ce tissu, créant un effet caractéristique translucide. Les reflets de la lumière sur la surface de la maille métallique sont obtenus avec l'utilisation du verre float extra clair, qui, grâce à un faible teneur de oxydes de fer, permet un maximum de transparence et de transmission de la lumière. Suite au procédé de stratification à chaud, le tissu peut présenter de petites ondulations, qui apportent au matériau son aspect caractéristique et naturel.

### VERRES LAQUÉS ECOLORSYSTEM

Ecolorsystem est le nom qui caractérise la collection exclusive de verres laqués de Rimadesio disponibles en finition brillante et mate. Couleurs écologiques, parce que produits en utilisant exclusivement vernis à l'eau de dernière génération, cuites à 110°. Une technologie de production avant-gardiste dans le domaine du verre, avec des équipements internes entièrement robotisés qui assurent des résultats de grande qualité et un cycle de production ayant un impact très faible sur l'environnement. Résistance à la corrosion conformément à la norme UNI EN ISO 9227. Résistance aux écarts de température conformément à la norme UNI 9429. Couleurs inaltérables parce qu'ils sont appliqués dans la surface interne du verre, pour protéger de la poussière humidité et taches. L'épaisseur du verre crée un exclusif effet profondeur.

### CRISTALES TEMPLADOS

Vidrios simples, sometidos al tratamiento de templado a una temperatura de cocción de 650 °C. Resistencia mecánica de 5 veces mayor que el vidrio normal. En caso de rotura, se desmoronan fragmentos inofensivos. Conforme a las normas UNI EN 12150, UNI 7697 y UNI EN 12600 en materia de seguridad para los cristales en el amueblamiento.

### CRISTALES ESTRATIFICADO

Vidrios dobles. Entre los dos vidrios hay una película fina de material plástico, transparente e invisible, que se adhiere completamente a las dos superficies. Ambas superficies son perfectamente lisas. La resistencia a la rotura cumple con las normas UNI EN ISO 12543, UNI 7697 y UNI EN 12600. La película de plástico en caso de rotura retiene los fragmentos.

### CRISTALES ESTRATIFICADOS RED METÁLICA, MAILLA Y FIBRA

Cristales dobles estratificados. Entre los dos cristales extraclaros y las dos capas sintéticas, está inserido en un tejido de microred en el que, a través de un sofisticado proceso se deposita una característica de efecto semitransparente. Los reflejos de la luz sobre la superficie de la red metálica se proporcionan con el uso del vidrio float extraclaro que, gracias a su bajo contenido en óxidos de hierro, asegura la máxima transparencia y una alta transmisión de luz. El tejido, siguiendo el proceso de estratificación en caliente, puede presentar ligeras ondulaciones que dan al material su aspecto característico natural.

### CRISTALES LACADOS ECOLORSYSTEM

Ecolorsystem es la denominación que marca la exclusiva colección de los cristales lacados Rimadesio, disponibles en acabado brillante y mate. Colores ecológicos porque productos utilizando exclusivamente pinturas al agua de última generación, con cocción a 110°. Una tecnología productiva a la vanguardia en el ámbito del cristal, con unas instalaciones internas totalmente robotizadas que aseguran resultados de altísima calidad y un ciclo de tratamiento respetuoso del medio ambiente. Resistencia a la corrosión conforme a la norma UNI EN ISO 9227. Resistencia a las variaciones de temperatura conforme a la norma UNI 9429. Colores inalterables en el tiempo porque aplicados en la superficie interior del cristal, al resguardo de manchas, polvo y humedad. El grosor del cristal crea un exclusivo efecto de "profundidad".

### ЗАКАЛЕННОЕ СТЕКЛО

Механическая прочность одинарных стекол, подвергнутых закалке, т.е. обжигу при температуре 650°С, в 5 раз выше, чем у обычного стекла. Если такое стекло разбить, оно рассыпется на мелкие неопасные осколки. Соответствует стандартам безопасности UNI EN 12150, UNI 7697 и UNI EN 12600 для мебельного стекла.

### МНОГОСЛОЙНОЕ СТЕКЛО

Двойные стекла. Тонкая, прозрачная и невидимая пластиковая пленка прокладывается между двумя стеклами и полностью приклеивается к обеим поверхностям. Обе поверхности идеально гладкие. Проверка прочности на разрыв была выполнена в соответствии со стандартами UNI EN ISO 12543, UNI 7697 и UNI EN 12600. Эта пленка способна удерживать осколки разбившегося стекла.

МНОГОСЛОЙНОЕ СТЕКЛО, СТЕКЛО С СЕТКОЙ Многослойное двойное стекло. Между двумя сверхпрозрачными стеклами и двумя тонкими пластиковыми пленками вставляется микросетчатое полотно, на которое в ходе сложного производственного процесса наносится металлический слой, благодаря чему и формируется характерный полупрозрачный эффект. Отражение света на поверхности металлизированной сетки достигается за счет использования сверхчистого флот-стекла, которое из-за низкого содержания оксида железа гарантирует максимальную прозрачность и высокую светопропускную способность.

В результате процесса наслаивания в горячем виде полотно приобретает небольшие волнистости, которые придают материалу характерную текстуру и натуральный вид.

### ЛАКИРОВАННОЕ СТЕКЛО

ECOLORSYSTEM Ecolorsystem — это название эксклюзивной коллекции лакированного стекла Rimadesio, доступной в глянцевой и матовой отделке. Коллекция характеризуется мягкими спокойными цветами, поскольку при их производстве используются только краски последнего поколения на водной основе, запекаемые при температуре 110°С. В стекольной промышленности в настоящее время внедряются современные производственные технологии, полностью роботизированные заводы, обеспечивающие высокое качество и незначительное воздействие на окружающую среду. Коррозионная стойкость соответствует требованиям положений стандарта EN ISO 9227. Устойчивость к изменениям температуры соответствует требованиям стандарта UNI 9429. Цвет характеризуется исключительной долговечностью, поскольку краски наносятся на внутреннюю поверхность стекла, защищенную от пятен, пыли и влаги. Толщина стекла создает уникальный эффект «глубины».

钢化玻璃 单片玻璃通过淬火工艺,即经 650 °C 高温烧制而成,其机械阻力相较于普通玻璃高出 5 倍。钢化玻璃破裂时会碎成不易伤人的细小碎片。符合家具玻璃安全材质 UNI EN 12150、UNI 7697 以及 UNI EN 12600 的标准。

### 夹层玻璃

双层玻璃。在两片玻璃之间夹有一层纤薄、透明、无形的塑料薄膜,其完全贴合两片玻璃的表面。两片玻璃的表面皆光滑无比。其抗裂性能符合 UNI EN ISO 12543、UNI 7697 以及 UNI EN 12600 的标准。玻璃破裂时,其碎片会粘在塑料薄膜上,裂而不散。

网夹层玻璃、网格夹层玻璃和纤维夹层玻璃 双层夹层玻璃。在两片超清玻璃和两层纤薄的塑料薄膜之间夹入一层微型网状织 物,一道细腻的材质加工工艺,会在织物上覆盖一层金属并创造出半透明的特殊效果。使用超清浮法玻璃产出金属网表面的光线反射,因玻璃的氧化铁含量低,可确保最大透明度和高透光率。通过热分层加工工艺,夹入的织物会有不平整的现象,从而呈现出具有特色的材质纹理和自然感的外观。

环保色彩系统 (Ecolorsystem) 的烤漆玻璃 Ecolorsystem 为 Rimadesio 烤漆玻璃独家系列的名称,有亮面和哑光两种表面处理可供选择。由于仅使用最新一代的水性涂料搭配 110°C 烘烤工序完成而被称为生态环保性色彩;其为超前玻璃业界的生产技术,而全机器人化的内部设备确保极高的产品质量和低环境冲击的加工循环。其抗腐蚀程度符合 UNI EN ISO 9227 的标准。其抗温度急变性符合 UNI 9429 的标准。因色彩涂层夹于玻璃内层,因此不会褪色且不受脏污、灰尘和湿气的影 响。玻璃的厚度创造出一种独特的“深度”效果。



ECOLORSYSTEM LACQUERED GLASS

GLOSSY MATT		GLOSSY MATT		GLOSSY MATT		GLOSSY MATT		GLOSSY MATT		GLOSSY MATT			
305	138 cipria	45	97 avorio	59	105 grigio chiaro	40	115 grigio cenere	53	95 bianco neve	50	108 bianco latte		
51	113 nocciola	52	107 corda	56	98 lino	312	145 grigio seta	47	96 grigio perla	78	114 sabbia		
306	139 terracotta	85	130 tufo	310	143 creta	38	121 azzurro cera	36	117 blu Londra	74	110 canapa		
76	116 rosso india	308	141 pepe	317	600 grigio artico	35	100 blu notte	39	122 verde inglese	73	109 giallo kashmir		
75	129 amaranto	309	142 sandalo	88	132 grigio scuro	86	131 blu oceano	314	147 verde lichene	43	119 laguna		
307	140 java	58	99 caffè	311	144 grigio lava	313	146 blu scuro	315	148 verde scuro	33	111 verde oliva		
		84	128 moro	46	102 nero					316	149 verde terra		

ECOLORSYSTEM SAHARA GLASS

551	nocciola sahara	552	corda sahara	517	lino sahara	512	grigio seta sahara	514	verde lichene sahara	574	canapa sahara
506	terracotta sahara	508	pepe sahara	524	grigio artico sahara	522	blu oceano sahara	515	verde scuro sahara	543	laguna sahara
507	amaranto sahara	509	sandalo sahara	521	grigio scuro sahara	513	blu scuro sahara			523	verde oliva sahara
540	java sahara	519	caffè sahara	511	grigio lava sahara						
		584	moro sahara	546	nero sahara						

ECOLORSYSTEM TAIGA GLASS

851	nocciola taiga	852	corda taiga	817	lino taiga	812	grigio seta taiga	814	verde lichene taiga	874	canapa taiga
806	terracotta taiga	808	pepe taiga	824	grigio artico taiga	822	blu oceano taiga	815	verde scuro taiga	843	laguna taiga
807	amaranto taiga	809	sandalo taiga	821	grigio scuro taiga	813	blu scuro taiga			823	verde oliva taiga
840	java taiga	819	caffè taiga	811	grigio lava taiga						
		884	moro taiga	846	nero taiga						

ECOLORSYSTEM METALIZED GLASS

GLOSSY MATT		SAHARA		TAIGA		DIAMANTE	
304	137 platino	504	platino sahara	804	platino taiga	404	platino diamante
69	126 palladio	569	palladio sahara	869	palladio taiga	469	palladio diamante
83	127 piombo	583	piombo sahara	883	piombo taiga	483	piombo diamante
301	134 peltro	501	peltro sahara	801	peltro taiga	401	peltro diamante
302	135 grafite	502	grafite sahara	802	grafite taiga	402	grafite diamante
303	136 bronzo	503	bronzo sahara	803	bronzo taiga	403	bronzo diamante
300	133 rame	500	rame sahara	800	rame taiga	400	rame diamante

NEUTRAL GLASS

55	specchio
68	specchio grigio

TRANSPARENT GLASS

890	trasparente taiga
590	trasparente sahara
490	trasparente diamante
05	trasparente extrachiaro
00	trasparente
63	grigio trasparente
65	bronzo trasparente
390	verde trasparente
391	blu trasparente

SATINATED GLASS

67	riflettente chiaro
64	riflettente grigio
81	riflettente bronzo
891	acidato taiga
591	acidato sahara
02	acidato extrachiaro
01	acidato
03	acidato grigio
04	acidato bronzo
82	nuvola extrachiaro
80	nuvola

MESH GLASS

60	rete alluminio
61	rete inox
62	rete bronzo
66	maglia gold
87	maglia rame
06	fibra argento
08	fibra bronzo

REFLEX GLASS

90	bianco reflex
92	kaki reflex
94	cacao reflex
89	nero reflex

















ECOLORSYSTEM MATT LACQUERED

 305 cipria	 45 avorio	 59 grigio chiaro	 40 grigio cenere	 53 bianco neve	 16 bianco latte
 51 nocciola	 52 corda	 56 lino	 312 grigio seta	 47 grigio perla	 78 sabbia
 306 terracotta	 85 tufo	 310 creta	 38 azzurro cera	 36 blu Londra	 74 canapa
 76 rosso india	 308 pepe	 317 grigio artico	 35 blu notte	 39 verde inglese	 73 giallo kashmir
 75 amaranto	 309 sandalo	 88 grigio scuro	 86 blu oceano	 314 verde lichene	 43 laguna
 307 java	 58 caffè	 311 grigio lava	 313 blu scuro	 315 verde scuro	 33 verde oliva
	 84 moro	 13 nero			 316 verde terra

ECOLORSYSTEM LACQUERED METALIZED

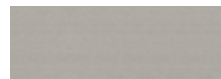
 304 platino	 302 grafite
 69 palladio	 303 bronzo
 83 piombo	 300 rame
 301 petro	

ALUMINIUM

 31 alluminio lucido
 30 alluminio
 14 brown
 318 nickel grigio
 22 nero lucido

LEATHER

 C23 bianco ghiaccio
 C17 sand
 C29 toupè
 C22 caramello
 C28 fango
 C11 moka

SYNTHETIC LEATHER

 157 arena
 158 agata
 155 nube
 154 argilla
 160 miele
 153 castoro
 159 etna
 156 rubens









LUX FABRIC

 T006 gesso
 T052 segale
 T044 acciaio
 T012 marmotta
 T042 ruggine
 T051 salvia

MATERIAL FABRIC

 T020 nebbia
 T019 papiro
 T009 piuma
 T017 roccia
 T001 terracotta
 T003 brandy
 T018 tabacco

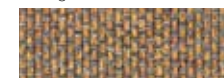
TECH FABRIC

 TT01 duna
 TT03 tortora
 TT05 mosto
 TT07 antracite
 TT09 fumo
 TT10 ghiaccio
 TT11 giada
 TT19 canyon
 TT20 dolomiti
 TT21 cedro



LITECH

 G001 crema
 G002 moka
 G003 pietra
 G004 grigio rigato

MARBLE

 28 calacatta
 184 crystal grey
 186 crystal brown
 180 emperador
 183 noir saint laurent
 187 verde lepanto
 182 rosso lepanto
 181 nero marquina

MATT MARBLE

 198 calacatta opaco
 194 crystal grey opaco
 191 nero marquina opaco
 185 crystal white opaco

WOOD

 711 rovere
 15 noce
 19 rovere termotrattato
 27 rovere nero
 710 tinto ebano

SAHARA WOOD

 17 noce sahara
 20 rovere termotrattato sahara



TAIGA WOOD

 701 rovere taiga
 700 tinto ebano taiga

MELAMINE

 07 melaminico olmo
 09 melaminico rovere grigio
 25 melaminico larice carbone

INTERNAL MELAMINE

 UB07 mel. cuoio grigio
 UB09 mel. cuoio brown

Collection designed by Giuseppe Bavuso.

# GRÜN BECK

RIMADESIO - WIEN . AT

interior architects | design brand stores

Margaretenstraße 93 | A-1050 Wien  
<https://rimadesio-wien.at>  
+43 1 306 35 41  
[rimadesio@gruenbeck.co.at](mailto:rimadesio@gruenbeck.co.at)

RIMADESIO SPA  
Via Furlanelli 96  
20833 Giussano (MB) Italy  
T +39 0362 3171  
[rimadesio@rimadesio.it](mailto:rimadesio@rimadesio.it)

MILANO FLAGSHIP STORE  
Via Visconti di Modrone 26  
20122 Milano Italy  
T +39 02 76280708  
[milano@rimadesio.it](mailto:milano@rimadesio.it)

LONDON FLAGSHIP STORE  
83-85, Wigmore street  
1WU 1DL London  
T +44 2074 862193  
[london@rimadesio.co.uk](mailto:london@rimadesio.co.uk)

NEW YORK FLAGSHIP STORE  
102 Madison Ave  
New York, NY 10016  
T +1 917 388 2650  
[usa@rimadesio.us](mailto:usa@rimadesio.us)

[www.rimadesio.it](http://www.rimadesio.it)

Art direction and graphic project: Juma  
Photo: Federico Cedrone, Santi Caleca  
Technical photo: F2 Fotografia  
Styling: Studiopepe; Patrizia Cantarella with Rossella Ballabio;  
Martina Lucatelli with Martina Dalla Bona;  
Simona Silenzi Studio; Gaia Marchesini and Giordano Sarno.

Thanks to: 101 Copenhagen, Agapecasa, Amini Carpets, Artemide, Atelier Interna, AYTM, B&B Italia, Bang & Olufsen, Beyond Object, Bitossi Ceramiche, Camp Design Gallery, Carl Hansen & Søn, Caussa, Danese Milano, Dany GILLES, Davide Groppi, Dechem Studio, Dedar Milano, ELOA - Unique Lights GmbH, Emil, Etel, Flos, Frette 1860, Gan Rugs, Gardeco, Henry Timi, iittala, J. & L. Lobmeyr, Kiasmo, Knoll International, Lanerossi, Living Divani, Louis Poulsen, Lumina, Mauro Bellucci, ESH Gallery Milano, Mmairo, Modern Lights, Nemo Lighting, Noorstad, Noorth, Numa Limited Editions, Officine Saffi, Pandul-Classic Modern Lights, Phantom Hands, Pineider 1774, Produzione Privata, Society Limonta, Tacchini Italia, TecnoLumen, Tenoha Milano, Terry Davies Ceramics, Unurgent Argilla, Vitra, When Objects Work.

Films and print: Optima  
Printed in Italy, 2024

#### AWARDS

1993	Siparium	Young & Design
2000	Zenit	Award KBB
2001	Zenit	selection Design Index ADI
2002	Siparium	Top100 Frames
2005	Graphis	selection Design Index ADI
2007	Vela	selection Design Index ADI
2008	Vela	mention XXI Premio Compasso d'Oro ADI
2015	Wind	winner Red Dot Award
2016	Cover	Best Furniture System AZ Award
2016	Alambra	selection Design Index ADI
2017	Sail	selection Design Index ADI
2017	Soho	Architectural products AZ awards
2017	Daimon	Interior Design Magazine Best of Year awards
2020	Modulor	People's Choice winner AZ Awards
2020	Modulor	Architectural Products Award of Merit AZ Awards
2020	Modulor	selection Design Index ADI
2021	Francis	selection Design Index ADI
2021	Modulor	LivingEtc Style Awards
2022	Maxi	selection Design Index ADI
2022	Aliante	finalist Interior's best of the Year awards
2022	Aliante	finalist A+Product awards
2023	Maxi	winner German Design Awards
2023	Radius	Architect's Newspaper's Best of Products Awards

#### PATENTED:

Radius, Aliante, Rialto, Maxi, Sail, Soho, Velaria, Stripe, Daimon, Graphis, Zen, Zen frame, Siparium, Moon, Vela, Luxor, Even, Aura, Spin, Link+, Planet, Flat, Alambra, Abacus living, Self, Cover, Zenit, Dress bold, Abacus.

#### REGISTERED TRADEMARKS:

Rimadesio, Colorsystem, Litech, Siparium, Velaria, Abacus.



Follow us on Instagram, Facebook, LinkedIn,  
WeChat, Weibo, Little Red Book.

